

**Schools**

**TOTAL ARMY SCHOOL SYSTEM**

---

**By Order of the Secretary of the Army:**

**EDWARD D. BACA**  
Lieutenant General, USA  
Chief, National Guard Bureau

**Official:**

**DEBORAH GILMORE**  
Chief  
Administrative Services

---

**Applicability.** This pamphlet applies to all ARNG units within all states, the Territory of Guam, the Commonwealth of Puerto Rico, and the District of Columbia. Subsequent reference to "the States" will be interpreted as inclusive of the Virgin Islands, the Territory of Guam, the Commonwealth of Puerto Rico, and the District of Columbia. This Pam applies to all ARNG personnel involved in the conduct of institutional military education and training.

**Impact on New Manning System.** This pamphlet does not contain information that affects the New Manning System.

**Interim changes.** Interim changes to this pamphlet are not official unless they are authenticated by the

Chief, Administrative Services. Users will destroy interim changes on their expiration dates unless sooner superseded or rescinded.

**Suggested improvements.** The proponent agency of this pamphlet is the Chief, National Guard Bureau. Users are invited to send comments and suggested improvements on DA Form 2028 (Recommended Changes to Publications and Blank Forms) directly to Chief, National Guard Bureau (NGB-ARO-T), 111 South George Mason Drive, Arlington, VA 22204-1382.

**Distribution: A**

---

**Contents** (Listed by paragraph number)

<b>Chapter</b>	<b>Para</b>	<b>Para</b>
<b>Chapter 1</b>		
<b>Introduction</b>		
Purpose	1-1	Coordinating Authority 2-6
References	1-2	ARNG/USAR relationship 2-7
Explanation of abbreviations and terms	1-3	
Total Army School System	1-4	
Responsibilities	1-5	
Objectives	1-6	
Course information	1-7	
Description of Active Duty for Training (ADT)	1-8	
		<b>Chapter 3</b>
		<b>Combat Arms Training Brigades (CATB)</b>
		Objectives 3-1
		Mission 3-2
		Functions and responsibilities of Combat Arms Training Brigade 3-3
		CATB Commander duties and responsibilities 3-4
		Concept of the operation 3-5
		Combat Arms Training Brigade locations 3-6
		Combat Arms Training Battalion locations 3-7
		Work groups and councils 3-8
		<b>Chapter 4</b>
		<b>Leadership Training Brigades (LTB)</b>
		Objectives 4-1
		Mission 4-2
<b>Chapter 2</b>		
<b>TASS Overview</b>		
Overview	2-1	
Description of state TASS organization	2-2	
TASS Combat Arms Training Brigades (CATB) and Leadership Training Brigades (LTB)	2-3	
TASS training battalions	2-4	
TASS training battalion relationship to training companies in other states	2-5	

Functions and responsibilities of Leadership Training Brigade	4-3	<b>Chapter 10</b>	<b>Para</b>
LTB Commander duties and responsibilities	4-4	<b>Aviation</b>	
NCOA Training Battalion and Battalion (-) Commander duties and responsibilities	4-5	Mission statement	10-1
OCS Training Battalion Commander duties and responsibilities	4-6	Concept of operation	10-2
Concept of the operation	4-7	<b>Chapter 11</b>	
Leadership Training Brigade locations	4-8	<b>Individual Training Branch (NGB-ARO-TI)</b>	
NCOA and OCS Battalion locations	4-9	Purpose	11-1
Work groups and councils	4-10	Vision	11-2
		Mission	11-3
		Objectives	11-4
		Schools structure development	11-4
		Resourcing	11-6
		Requiements (Reserve Component ATRRS Life Cycle Management) - ATRRS	11-7
		Intermediate goals	10-8
		Noncommissioned Officer Education System (NCOES)	11-9
		Officer Education System (OES)	11-10
		Warrant Officer Education System (WOES)	11-11
<b>Chapter 5</b>		<b>Chapter 12</b>	
<b>Regional Training Institute</b>		<b>Training Management</b>	
Objectives	5-1	Individual Training Management Life Cycle	12-1
Mission	5-2	Total Army Centralized Individual Training Solicitation (TACITS)	12-2
RTI Commander duties and responsibilities	5-3	Training requirements generation	12-3
Concept of the operation	5-4	Structure Manning Decision Review (SMDR)	12-4
Membership	5-5	School codes	12-5
		Training outside functional alignment	12-6
<b>Chapter 6</b>		<b>Chapter 13</b>	
<b>General Studies Battalion</b>		<b>Resourcing TASS and Staff Responsibilities</b>	
Objectives	6-1	Objectives	13-1
Mission	6-2	Resources	13-2
General Studies Battalion functions and responsibilities	6-3	Functions and responsibilities of the TASS staff	13-3
GS BN Commander duties and responsibilities	6-4		
General Studies Battalion relationship to TASS Training Companies in the State	6-5		
General Studies Battalion relationship to TASS Training Battalions	6-6	<b>Chapter 14</b>	
Leadership Training Company	6-7	<b>Multi-Functional Training Brigades</b>	
Leadership Training Company mission	6-8	OCONUS ARNG TASS Multi-Functional Training Brigades	14-1
Combat Arms Training Companies	6-9	Region C	14-2
Combat Arms Training Company mission	6-10	Region G	14-3
State Officer Candidate School (OCS) Training Company mission	6-11		
Ordnance Training Company mission	6-12	<b>Glossary</b>	
<b>Chapter 7</b>		<b>Chapter 1</b>	
<b>Engineer Training Battalion</b>		<b>Introduction</b>	
Objectives	7-1	<b>1-1. Purpose</b>	
Mission	7-2	This Army National Guard (ARNG) Pamphlet (Pam) on the Total Army School System (TASS) serves as guidance for the management of Individual Military Education and Training (IMET) in the ARNG. This Pam formally recognizes the TASS ARNG Training Brigades, Training Battalions, General Studies Battalion (GSB), Training Companies, and Regional Training Institutes (RTI) within TASS. It is also a reference for ARNG TASS actions.	
EN TNG BN Commander duties and responsibilities	7-3		
<b>Chapter 8</b>			
<b>Ordnance Training Battalion</b>			
Objectives	8-1		
Mission	8-2		
OD TNG BN Commander duties and responsibilities	8-3		
TASS Ordnance relationships	8-4		
Locations of Ordnance Battalions	8-5		
Locations of Ordnance Companies	8-6		
<b>Chapter 9</b>			
<b>Recruiting and Retention Battalion</b>			
Objectives	9-1		
Mission	9-2		

**1-2. References**

- a. **AR 351-1** (Individual Military Education and Training).
- b. **AR 611-101** (Commissioned Officer Classification System).
- c. **NGR 351-1** (Individual Military Education and Training).
- d. **NGR 600-200** (Enlisted Personnel Management).

**1-3. Explanation of abbreviations**

Abbreviations used in this pamphlet are explained in the **Glossary**.

**1-4. Total Army School System**

The TASS is a term that includes all National Guard Bureau (NGB) sponsored regional and specialty schools, Training Brigades and Battalions, RTIs, Army Area schools, United States Army Reserve (USAR) TASS schools, other Reserve Component (RC) training facilities that conduct formal individual training and Active Component (AC) training institutes.

**1-5. Responsibilities****a. Chief, National Guard Bureau (CNGB).**

- (1) Manages the ARNG IMET program.
- (2) Manages ARNG school accounts Modified Army Management Structure Code (MAMSCO) 2F to ensure resources are equitably distributed to all States.
- (3) Forecasts Army Service, Department of Defense (DOD or DD), and RC school requirements and obtains quotas based on input from the States through the Army Training Requirements and Resources System (ATRRS).
- (4) Processes selected ATRRS Army Automated Training Applications (AATAS); NGB Form 64 (Application for Training); DD Forms 1610 (Request and Authorization for Temporary Duty (TDY) (Travel of DOD Personnel); DD Forms 1556 (Request, Authorization, Agreement, Certification of Training and Reimbursement); and issues authority for States to publish orders to attend training.
- (5) Processes applications for waiver related to individual training matters.
- (6) Participates in TASS activities at Regional and National levels.

**b. State POTOs.**

- (1) Manage State IMET program.
- (2) Forecast training requirements in Army service, DOD and TASS Schools and provide the data to NGB-ARO-TI.
- (3) Process school applications; ensure applicant eligibility.
- (4) Process waiver requests.
- (5) Prepare orders directing ARNG personnel to attend schools as authorized by NGB-ARO-TI.
- (6) Participate in TASS activities at Regional/State level.
- (7) Manage state school program budget account (MAMSCO 2F) as resourced by NGB.

**c. Schoolhouses.** See chapters 3, 4, and 5 for information regarding BDE and RTI responsibilities

**d. Commanders.**

- (1) Identify training requirements.
- (2) Ensure that soldiers meet physical fitness standards in accordance with AR 351-1, AR 350-41, Chapter 9 and Federal Travel Regulation (FTR) 135-3.
- (3) Ensure that soldiers meet the standards of AR 600-9 when reporting for all training. Failure to meet these standards is sufficient cause for the student to be denied enrollment and returned to home station unqualified.

**e. Individuals.**

- (1) Responsible for meeting physical fitness standards in accordance with AR 351-1, AR 350-41, Chapter 9 and FTR 135-3.
- (2) Responsible for meeting the standards of AR 600-9 when reporting for all training. Failure to meet these standards is sufficient cause for the student to be denied enrollment and returned to home station unqualified.

**1-6. Objectives**

- a. Provide a TASS implementation vehicle for use by all states.
- b. Establish the command, coordination, and operational procedures among states, Training (TNG) Brigades (BDE), TNG Battalions (BN) and Training Companies/Batteries.
- c. Develop working relationships between the TNG BDEs and other agencies/organizations (SMDR, RTC, TAAC, RCE Work Group).
- d. Establish the state TASS structure and show how it builds on the TNG BN, TNG BDE and Regional concept.
- e. Establish functional alignment of TNG BNs with their proponent school missions.
- f. Explain how each state participates in the ARNG TASS organization.
- g. Explain coordination between ARNG and United States Army Reserve Command (USARC) for Ordnance, Engineer, and NCOES organizations.
- h. Explain the integration process of the Regional Training Site-Maintenance (RTS-M), Reserve Component Armor Training Center (RCTCC), Regional NCO Academies, Engineer School, Eastern Army Aviation Training Site (EAATS), Western Army Aviation Training Site (WAATS).
- i. Develop basis for interstate guidance/policy for cross-state missioning, support and conduct of training under TASS.
- j. Develop basis for cross-component guidance/policy among ARNG, USARC, and DA for cross-component missioning, support and conduct of training under TASS.

**1-7. Course information**

ATRRS contains pertinent information about individual training courses and should be reviewed by personnel preparing applications. Course prerequisites, school/class location, reporting information, and available transportation means are some of the ATRRS data included herein.

**1-8. Description of Active Duty for Training (ADT)**

**a.** For purposes of this Pam, ADT is defined as active duty training, with or without pay, authorized for ARNG members under Title 32, United States Code, sections 504 and 505. This duty is performed under State jurisdiction as opposed to Federal jurisdiction, and includes attendance at TASS schools.

**b.** ARNG personnel attendance at TASS schools in an ADT status will receive not less than eight hours of Program of Instruction (POI) training each day during the training period. At least seven hours of POI training will be conducted both the first day and the last day of training periods when the training is 2 or more days in duration. Allowances will be made for RTIs and brigades to determine what is the most efficient use of time and resources as long as local policies are not abusive.

**c.** For purposes of this Pam, orientations, critiques, and graduation ceremonies are considered to be legitimate POI subjects as long as none of them exceed 1 hour duration. Travel, sign-in or sign-out, issue or turn-in of equipment, administrative time, commandant's time, and time allowed for troop messing/rest periods are not considered legitimate POI subjects.

**Chapter 2  
TASS Overview**

**2-1. Overview**

**a.** The Total Army School System (TASS) is a tri-component organization involving AC, the ARNG, and the USAR. The TASS concept divides the continental United States into seven geographic regions. The regional concept was determined by factors such as geographic data, demographic profile, and the force structure of all three components. **Figure 2-1** represents the regional structure of the TASS.

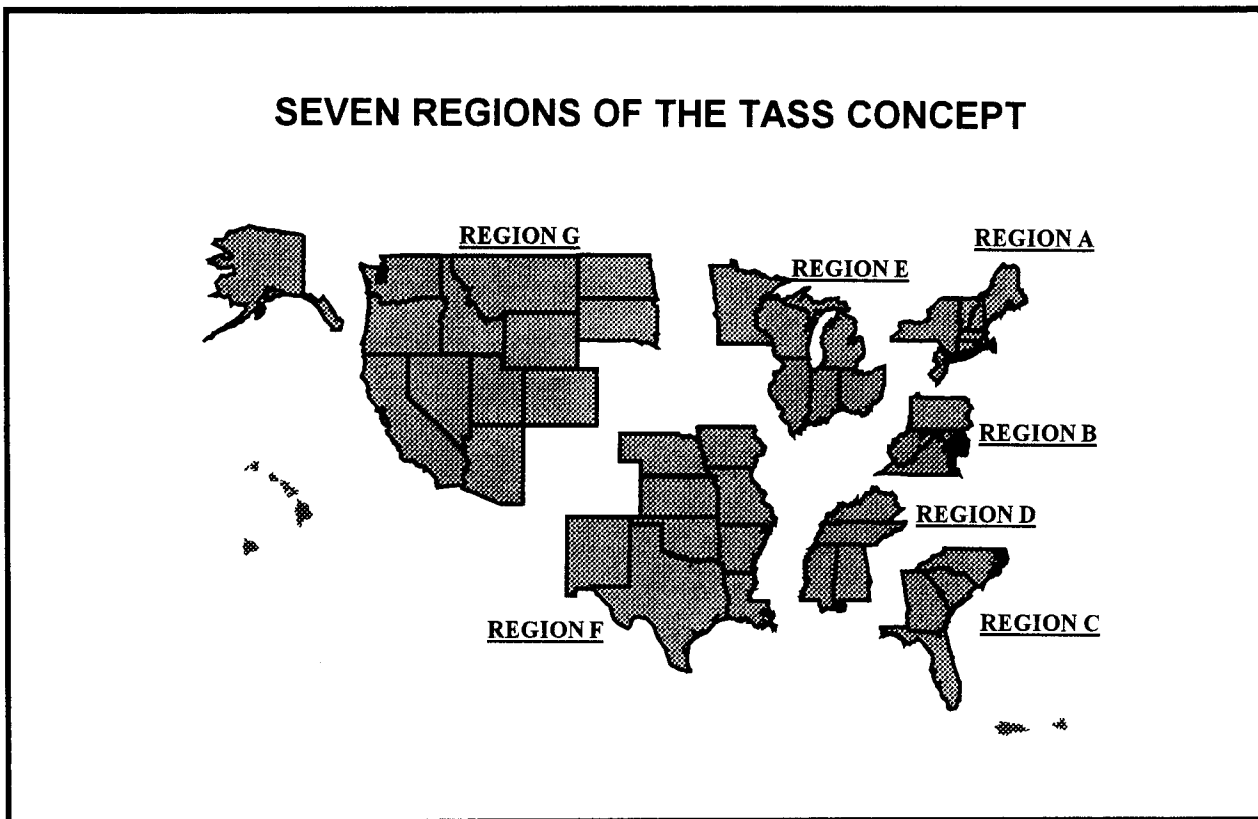

**Figure 2-1. Seven TASS Regions**

**b.** Each region contains six training brigades. The brigades oversee instruction in the following areas: Leadership (LDR), Professional Development (PD), Health Services (HS), Combat Arms (CA), Combat Support (CS), and Combat Service Support (CSS). Within each brigade are battalions. The battalions are functionally aligned with the AC proponent for that particular Career Management Field (CMF). For example, Artillery Training Battalions, responsible for

all artillery training within the Region, are aligned with the Artillery School at Fort Sill. The ARNG has responsibility for two TASS brigade missions; Combat Arms and Leadership. Furthermore, the ARNG has three Multi-Functional (MF) Training Brigades. These MF brigades provide training for the Outside Continental United States (OCONUS) elements. There is one BDE each in Alaska, Hawaii, and Puerto Rico. **Chapter 13** discusses the MF BDEs.

c. Overall responsibility for TASS belongs to Headquarters (HQ) Training and Doctrine Command (TRADOC). The TRADOC Coordinating Element (TCE) has been established to help implement TASS. Coordination lines are established among the three components (AC/ARNG/USAR) to establish TASS. Within each region, a Regional Coordinating Element

(RCE) was established in each region to coordinate TASS operations. The RCE acts as a coordinating element between the AC, ARNG and USAR within a Region and works under the TCE. The chart in Figure 2-2 identifies the overview of the TASS organization and the tri-component relationship. FY 96 was the implementation year and FY 97 is the execution year.

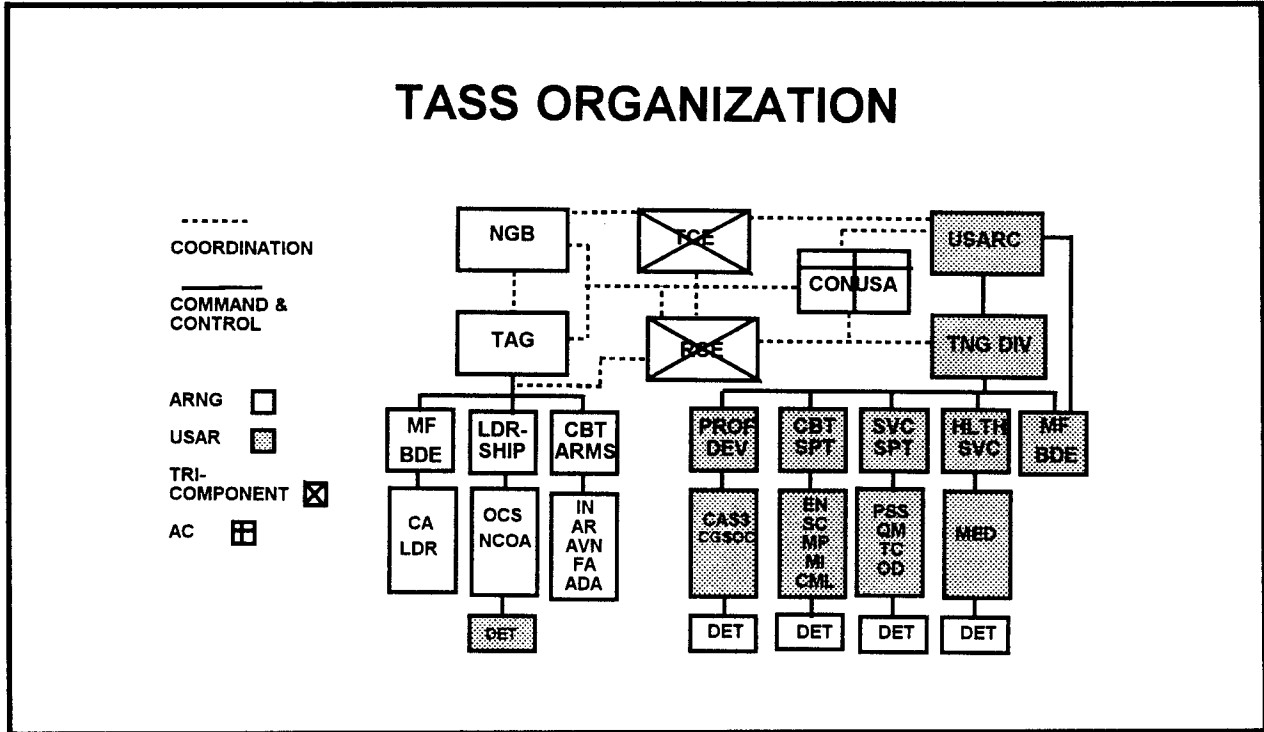

Figure 2-2. TASS Organization

d. The ARNG is organized with each state having command and control (C2) over their state National Guard. State Governors and the Adjutants General (TAG) direct all National Guard actions and training for the state. To accomplish TASS missions within and across state boundaries, the NGB and the TAGs developed the CATB, LTB, and the Regional Training Institutes (RTI). Each CATB, LTB or RTI contains functionally aligned TASS TNG BNs or a GS TNG BN. Under the BNs, there are functionally aligned Combat Arms Training Companies, OCS Training Companies, and Leadership Training Companies. TASS Training BNs are functionally aligned to a proponent school and have coordinating authority to conduct regional TASS missions as directed by the Army Programs for Individual Training (ARPRINT) and missioned by ATRRS.

**2-2. Description of state TASS organizations**

Each state is organized as either a CATB, a LTB, or a RTI. The CATB, LTB and RTIs are equal; however, they have different levels of responsibility across state lines. Each state has a schoolhouse C2 element. Most states have an RTI which verifies and coordinates missions, manages personnel, and provides equipment support within the state. In each region, there is

a CATB in one state and a LTB in another state. In addition to the RTI responsibilities stated above, the CATB and LTB are the chief integrators for quality assurance (QA) in combat arms and leadership training throughout the region. A training brigade/battalion exercises coordinating authority to ensure training is conducted to standard in other states within the region. This includes support activities for the conduct of training. The TNG BDE monitors the training battalions' execution of training missions and provides assistance as necessary. ADT missions are conducted with additional assets from other states within the region. Cross state coordination is conducted through appropriate command channels.

**2-3. TASS Combat Arms Training Brigades (CATB) and Leadership Training Brigades (LTB)**

The CATB and LTB are two of the six TASS TNG BDEs responsible for execution of training in each region. The CATB and LTB are under the command and control of the respective state TAG. Command and control for the four USAR TNG BDEs (PD, HS, CS, and CSS) resides with the USAR Division, Individual Training, DIV(IT). Figure 2-3 depicts RC BDE organization. The CATB and LTB participate annually

in the Regional Pre-SMDR. The Regional Pre-SMDR includes the ARNG and USAR Training Brigades that accurately identify and validate training requirements.

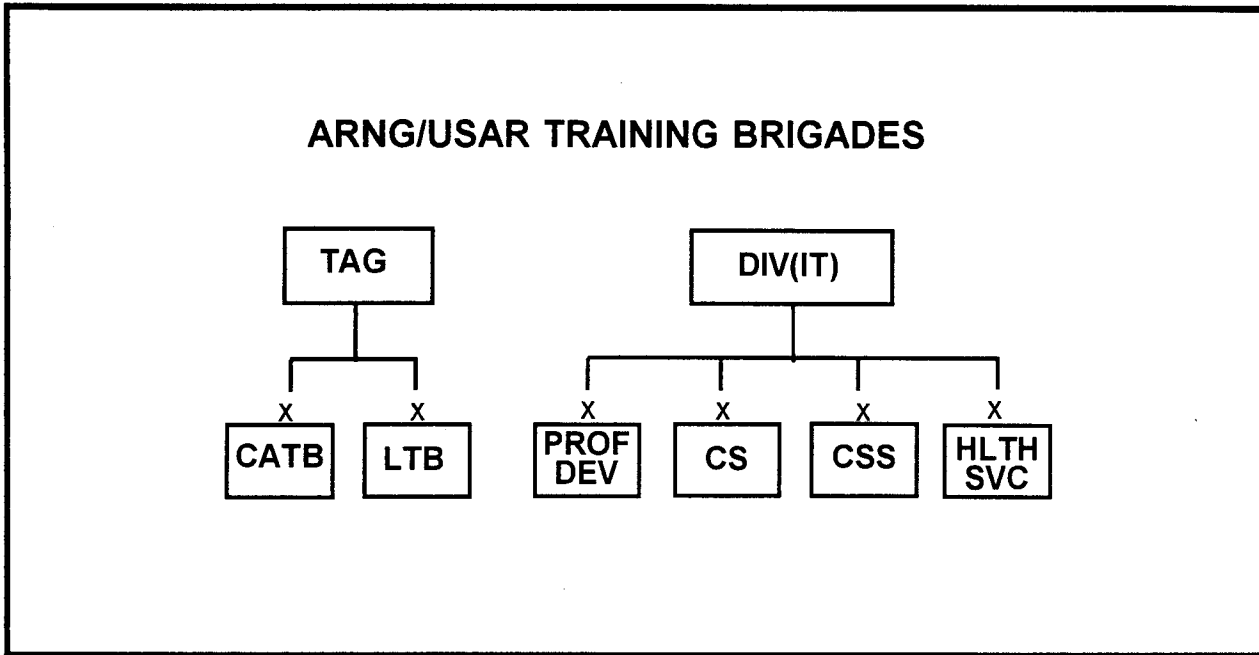

**Figure 2-3.** TASS Training Brigades

**2-4. TASS Training Battalions**

The TASS TNG BN is a functionally aligned organization that executes ADT classes and coordinates IDT classes in other states. It is accredited by the respective proponent school. The TNG BN maintains accountability of instructor and student records. The TASS TNG BNs perform direct coordination with the proponent school. The TNG BNs maintain administrative/operational accountability for accreditation through the school staff. The conduct of training records will be maintained at the school code where the training occurs. The TNG BNs process waiver requests to the proponent school with a copy furnished to the TNG BDE and the RCE. The TNG BN ensures that all formal actions are sent through the Plans, Operations, Training Officer (POTO) of the state and then to the receiving agency (NGB or USAR). Two Title XI soldiers are assigned to each TNG BN to assist with accreditation, instructor certification, quality assurance, and conduct of training. TASS TNG BNs submit ammunition requests to the TNG BDE. The TNG BDE consolidates this information and submits it to the RCE. **Figure 2-4** shows the TASS BNs in the combat arms and leadership areas.

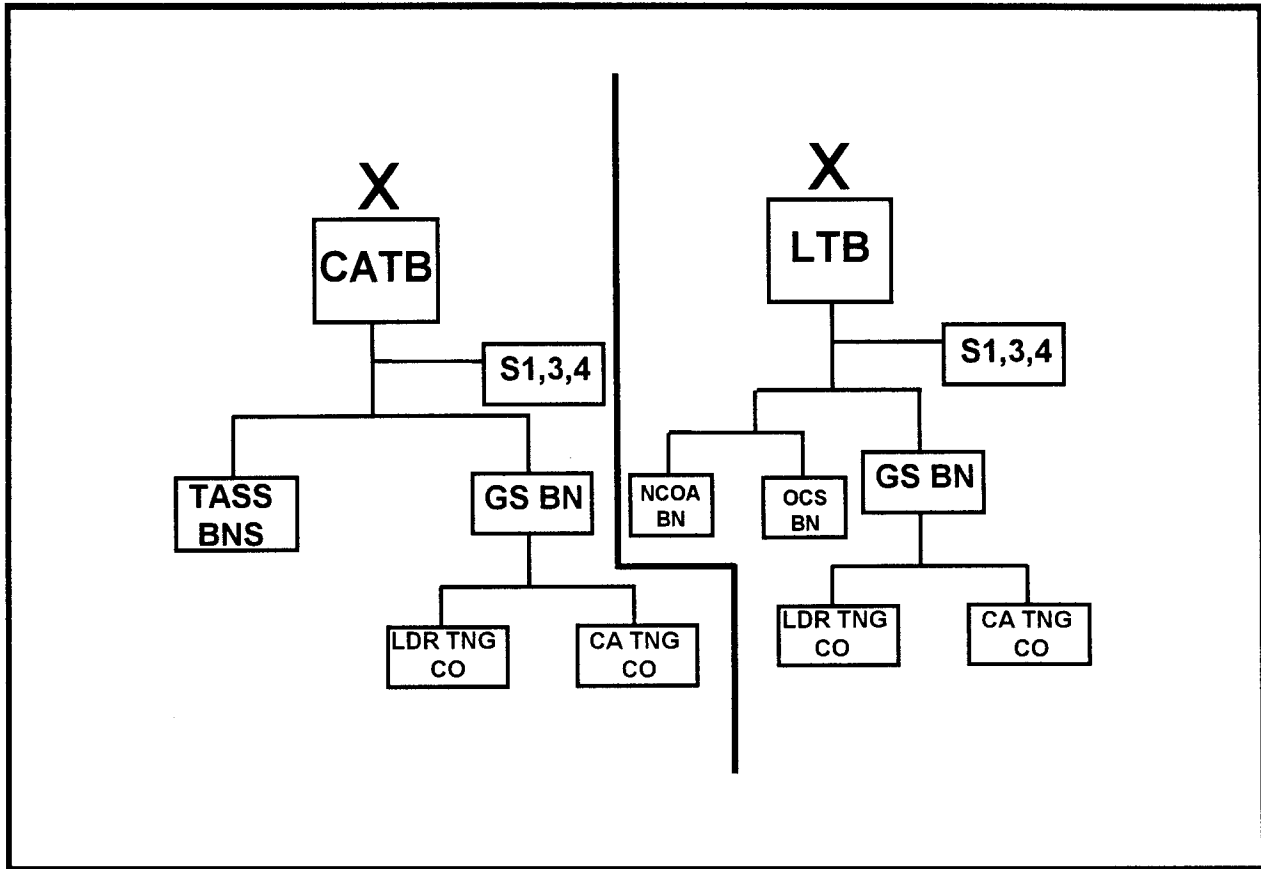

Figure 2-4. Sample Brigade Organization

#### 2-5. TASS training battalion relationship to training companies in other states

The Combat Arms Training Company and the Leadership Training Company execute IDT/ADT training missions coordinated by its functionally aligned TASS TNG BN (possibly in another state). These missions are listed in ATRRS. The execution of these coordinated missions directly affects the accreditation of the TNG BN. A percentage of the IDT sites will be evaluated by the proponent school during the accreditation process. The results of all IDT/ADT evaluations are consolidated into the TNG BN accreditation. If a training company/battery is not conducting classes to standard, notification is made through established channels. A period of time is given for corrections to be made. The TNG BN provides assistance as coordinated by the training company. Continued QA problems will be elevated to the TNG BDE. The TNG BDE will elevate these issues to the TASS Action Team, NGB-ARO-TI. The training company's ability to train and subsequent removal of courses from ATRRS will be considered and evaluated by the TASS Action Team.

#### 2-6. Coordinating Authority

*a.* Coordinating authority is not command and control. It is coordination of training missions across state

boundaries. It involves coordination to execute a TASS mission across funding lines to ensure resources are available to execute training. The coordinating authority objective is to formalize coordination for:

- (1) Accreditation.
- (2) Resourcing.
- (3) Communication for training missions/sites.
- (4) Instructor support.
- (5) Facilities support.
- (6) Establish training ownership.

*b.* Coordinating authority defines Training Brigade and Battalion levels of responsibility. It ensures functional alignment for conduct of training. Implementation of regional Memorandum of Agreement (MOA)/Memorandum of Understanding (MOU) Policy will be the instruments that define agreements for the training support. Policy and guidance letters will define agreements for the execution of training.

#### 2-7. ARNG/USAR relationship

The USAR will maintain the USAR chain of command for personnel actions, pay, and Uniform Code of Military Justice (UCMJ). During the conduct of training, the ARNG will execute command and control over all ARNG soldiers within their states and coordinating authority over soldiers in other states or agencies to

execute the mission. In cases where ARNG personnel are supporting USAR training missions, the ARNG maintains command and control for personnel actions, pay, and UCMJ. For training, the USAR will execute coordinating authority to ensure training missions are completed.

### Chapter 3 Combat Arms Training Brigades (CATB)

#### 3-1. Objectives

- a. Document the mission and organizational structure of the CATB.
- b. Provide guidance concerning the duties and responsibilities of the CATB.

#### 3-2. Mission

a. The CATB provides regionalized combat arms individual training including Military Occupational Specialty (MOS), Duty MOS Qualification (DMOSQ) Reclassification, Additional Skill Identifier (ASI), Non-commissioned Officer Education System (NCOES), and General Studies (GS) training for the ARNG, the USAR, and AC. The CATB performs regionalized management and QA oversight for the functionally aligned TASS TNG BNs. The CATB works in conjunction with the NGB, the RCE and TRADOC combat arms proponent schools (Armor, Infantry, Field Artillery, Air Defense Artillery, Aviation). The CATB monitors and coordinates academic instruction, facilities, food service and lodging for soldiers participating in training conducted at the RTI's training sites.

b. The CATB manages training based on training requirements obtained from NGB-ARO-TI, the ARPRINT, and the Training Requirements Arbitration Panel (TRAP). Training guidance will be used to plan and program the conduct of combat arms individual training within the region. Additional courses to be added by the TNG BNs must be approved by the CATB and submitted to the ARNG TASS Action Team for final approval.

c. The CATB uses coordinating authority to issue guidance, and to plan/program the conduct of combat arms individual training within the region.

#### 3-3. Functions and responsibilities of Combat Arms Training Brigade

- a. Executes all combat arms individual training within the state.
- b. Uses ATRRS in support of all individual training.
- c. Coordinates training ammunition requirements.
- d. Coordinates accreditation dates for TNG BNs.
- e. Ensures operational, administrative and logistics support occurs for the TNG BNs in the state.
- f. Identifies and executes instructor certification requirements.
- g. Identifies cross component training and resourcing problems to the RCE for resolution.
- h. Serves as a regional focal point for CMF training.
- i. Verifies that quality training is taking place.

#### 3-4. CATB Commander duties and responsibilities

- a. Trains subordinate staff and TNG BN commanders based on current Army doctrine and accomplishes the training mission IAW AR 351-1.
- b. Develops a Training Brigade Mission Essential Task List (METL).
- c. Ensures training is realistic, safe and challenging while adhering to approved TRADOC POIs.
- d. Performs necessary QA of Combat Arms TNG BNs in each region.
- e. Provides oversight of resource acquisition to Combat Arms TNG BNs
- f. Consolidates and processes requests to add courses on ATRRS. Recommends courses to the TASS Action Team. If approved, NGB-ARO-TI will load on ATRRS.
- g. Processes action to discontinue a course. Action is initiated after a period of time is allowed for corrective action. If deficiencies are not corrected, CATB requests NGB action to take a course off ATRRS. Action is completed when the course is removed from the school code for instructional offerings.
- h. Maintains records for ammunition and training as specified by the TCE.
- i. Consolidates TASS TNG BN ammunition requirements and submits to the RCE.
- j. Monitors waiver requests.
- k. Facilitates combat arms training actions with state POTOs, RCE, proponent schools, DIV(ITs), and NGB.
- l. Coordinates with the proponent school regarding combat arms training.
- m. Assists in coordinating administrative and logistical support for the Combat Arms TNG BNs.
- n. Coordinates accreditation visits with the accreditation team and ensures accurate and fair evaluations. It is not necessary for the TNG BDE to be present for the TNG BN accreditation.
- o. Ensures student records are maintained to standard.
- p. Oversees instructor certification process.
- q. Coordinates acceptance testing with NGB.
- r. Ensures timely and continuous instructor data base maintenance.
- s. Processes all additional off line courses recommended by the TNG BNs to NGB-ARO-TI.

#### 3-5. Concept of the operation

- a. Through ATRRS, the State POTO selects and assigns individual soldiers who will participate in prescribed Combat Arms MOSQ, ASI, and NCOES training. Funding is allocated by NGB through each respective state POTO.
- b. TASS TNG BNs administer Combat Arms training under the auspices of the TRADOC proponent schools.
- c. ADT training missions will be conducted at locations designated by NGB-ARO-TI.



**3-6. Combat Arms Training Brigade locations**

Region A	Fort Dix, New Jersey
Region B	Fort Indiantown Gap, Pennsylvania
Region C	Fort Bragg, North Carolina
Region D	Fort Knox, Kentucky
Region E	Camp Atterbury, Indiana
Region F	Camp Mabry, Texas
Region G	Camp San Luis Obispo, California

**3-7. Combat Arms Training Battalion locations**

<b>Region A</b>	
Armor	New Jersey
Field Artillery	Massachusetts
Infantry	Vermont
<b>Region B</b>	
Armor	Pennsylvania
Field Artillery	Virginia
Infantry	Virginia
Air Defense Artillery	Virginia
Aviation	Pennsylvania
<b>Region C</b>	
Armor	South Carolina
Field Artillery	North Carolina
Infantry	Georgia
Air Defense Artillery	Florida
<b>Region D</b>	
Armor	Tennessee
Field Artillery	Tennessee
Infantry	Mississippi
Air Defense Artillery	Alabama
<b>Region E</b>	
Armor	Ohio
Field Artillery	Wisconsin
Infantry	Michigan
Air Defense Artillery	Illinois
<b>Region F</b>	
Armor	Texas
Field Artillery	Oklahoma
Infantry	Arkansas
Air Defense Artillery	New Mexico
<b>Region G</b>	
Armor	Idaho
Field Artillery	Wyoming
Infantry	California
Aviation	Arizona

**3-8. Work groups and councils**

- a. Regional Reserve Component Pre-Structure Manning Decision Review (SMDR).
- b. NGB/USARC Reserve Component Pre-SMDR.
- c. Regional Training Council (RTC).
- d. Training Administrator Advisory Council (TAAC).
- e. RCE Work Group.

**Chapter 4  
Leadership Training Brigades (LTB)****4-1. Objectives**

- a. Document the mission and organizational structure of the LTB.
- b. Provide guidance concerning the duties and responsibilities of the LTB.

**4-2. Mission**

a. The LTB provides regionalized leadership, NCOES, OCS, and General Studies (GS) training for the ARNG, the USAR, and the AC. The LTB also performs regionalized management and QA oversight for the functionally aligned TASS TNG BNs. The LTB works in conjunction with the NGB, the RCE, TRADOC proponent schools, United States Army Sergeants Major Academy (USASMA) and United States Army Officer Candidate School (OCS). The LTB monitors and coordinates academic instruction, facilities, food service and lodging for soldiers participating in courses and training conducted at the LTB's training sites.

b. The LTB manages training the same as the CATB. See chapter 3 for details.

c. The LTB uses coordinating authority to issue guidance, and to plan/program the conduct of leadership individual training within the region.

**4-3. Functions and responsibilities of Leadership Training Brigade**

The LTB has the same functions and responsibilities as the CATB. See chapter 3 for details.

**4-4. LTB Commander duties and responsibilities**

The LTB CDR has the same duties and responsibilities as the CATB CDR (see chapter 3 for details) with the exception of the following:

- a. The host TNG BDE of OCS Phase III coordinates with other LTB for staffing and other assistance. The host TNG BDE also budgets for Phase III requirements.
- b. Supports the OCS TNG BNs requests for military air.

**4-5. NCOA Training Battalion and Battalion (-) Commander duties and responsibilities**

a. Provides all PLDC instruction in the region and ADT ANCOB/BNCOC Phase I training.

b. Monitors all IDT CLT ANCOB/BNCOC training at RTI or BDE.

c. Maximizes use of USAR instructors for IDT instruction.

d. Utilizes Title XI soldiers to assist with quality of instruction and instructor certification. Title XI soldiers are not primary instructors.

e. The NCOA Battalion and NCOA Battalion (-) will maintain separate records.

f. In regions A, E, and G, the USAR has the responsibility for the NCOA TNG BNs. The following items describe how the responsibility is shared in this unique situation:

(1) **Regions A and E NCOA TNG BNs (USAR).** (See Fig 4-1.)

(a) Command and control of the NCOA TNG BNs in Regions A and E falls under the USAR. This TNG BN is responsible for all regional NCOES institutional training.

(b) The Regional LTB has the responsibility for the TASS training mission. All PLDC and BNCOC/ANCOC ADT/IDT are accomplished through the NCOA Training Battalion (USAR).

(c) Uses coordinating authority to accomplish functional alignment with the Leadership Training Companies.

(d) Ensures the maintenance of the publications library and control of classified materials. This includes maintenance of test materials, regional test control, and identifying a Test Control Officer (TCO) on orders.

(e) Consolidates and processes all requests for training materials for the region with the RCE.

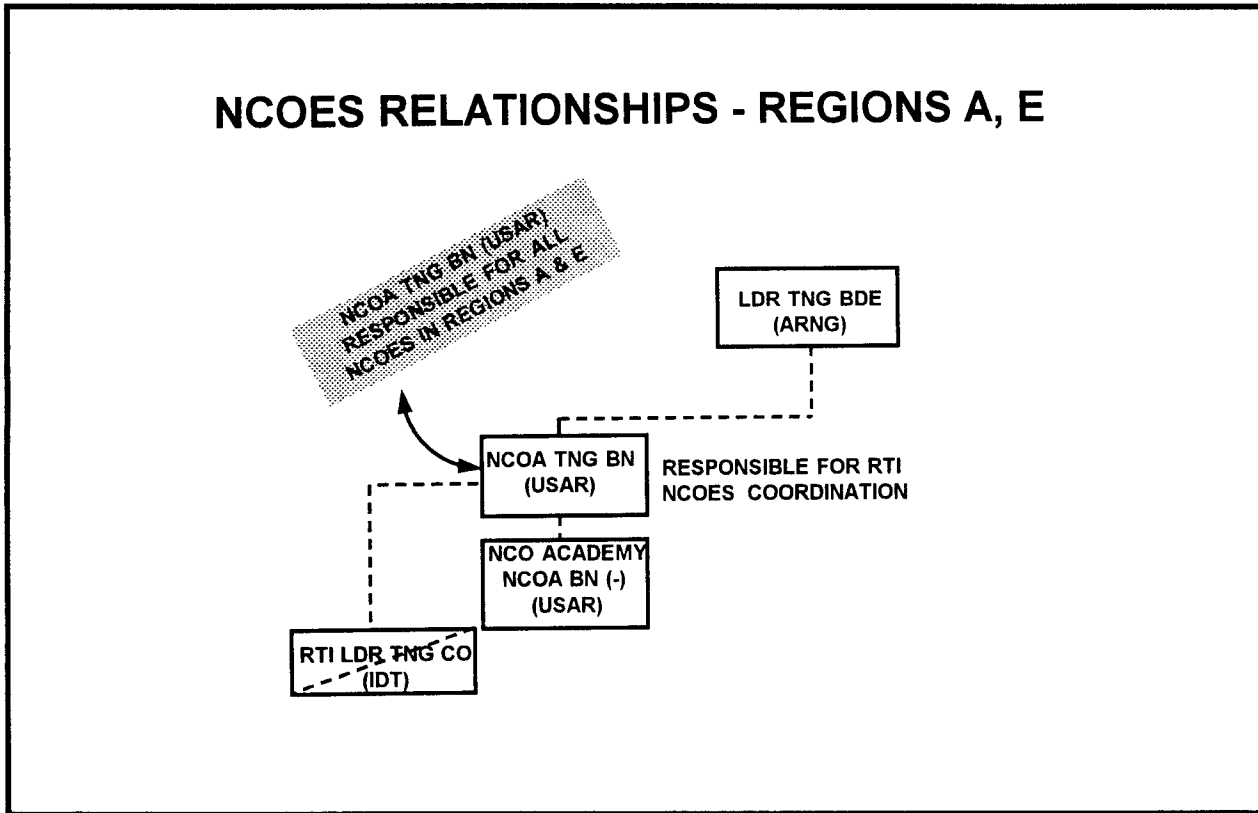

Figure 4-1. NCOES Relationships - Regions A and E

**(2) Region G NCOA TNG BN (USAR)/ NCOA TNG BN (-) (ARNG).** (See Fig 4-2.)

(a) Command and control for the NCOA TNG BN falls under the 104 DIV(IT). This TNG BN is responsible for all regional NCOES institutional training.

(b) The NCOA TNG BN (-) in the Western LTB remains under the command and control of the Utah ARNG. It operates within the coordinating authority of the Western LTB.

(c) The NCOA TNG BN and NCOA TNG BN (-) will exercise coordinating authority in conduct of the TASS training mission, but the NCOA TNG BN (-) will be missioned by NGB-ARO-TI.

(d) Execution of the TASS training mission will be coordinated through the Western LTB. All PLDC and BNCOC/ANCOC ADT courses are accomplished at the NCOA TNG BN (USAR) or NCOA TNG BN (-) (ARNG). The IDT BNCOC/ANCOC is coordinated by

the NCOA TNG BN with each RTI. The RTI, through each GS BN, executes NCOES in the Leadership Training Company.

(e) Uses coordinating authority to accomplish functional alignment with the Leadership Training Companies.

(f) Ensures the maintenance of the publications library and control of classified materials. This includes maintenance of test materials, regional test control, and identifying a TCO on orders.

(g) Consolidates and processes all requests for training materials for the region with the RCE.

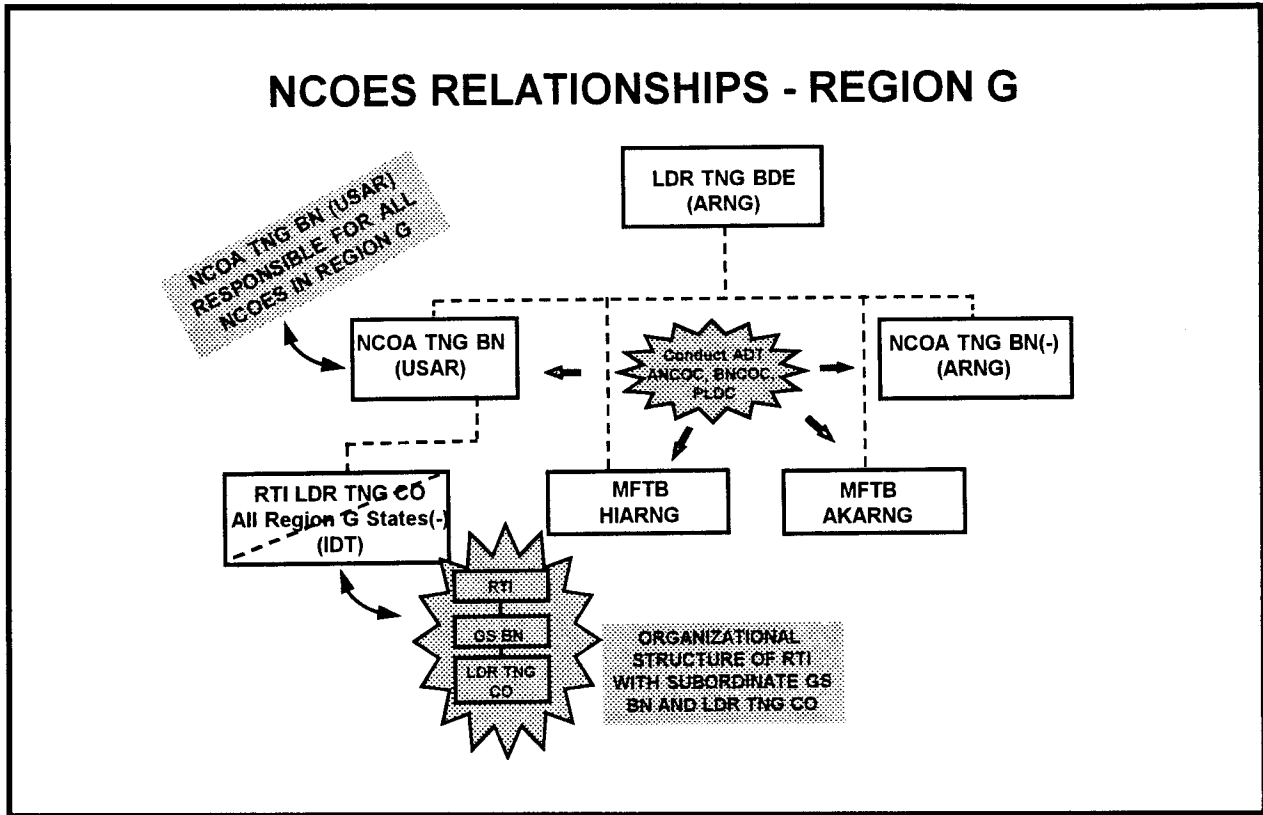

Figure 4-2. NCOES Relationships - Region G

**4-6. OCS Training Battalion Commander duties and responsibilities**

**a.** Coordinates and conducts regionally consolidated Phase I OCS. (See Figure 4-3.) Resources from the region will be consolidated from the OCS TNG COs to assist in the conduct of Phase I.

**b.** Assists with Phase II OCS. This will be done as determined by the states in the region and the regional OCS BN CDR.

**c.** Assists in consolidated Phase III training.

**d.** Consolidations of Phase III, or any other consolidations above the region will be the responsibility of the LTB. The LTB that hosts Phase III will coordinate staffing and other assistance with other LTBs and their OCS BN CDRs.

**e.** Identifies Active Duty Special Work (ADSW) requirements for Phases I and III.

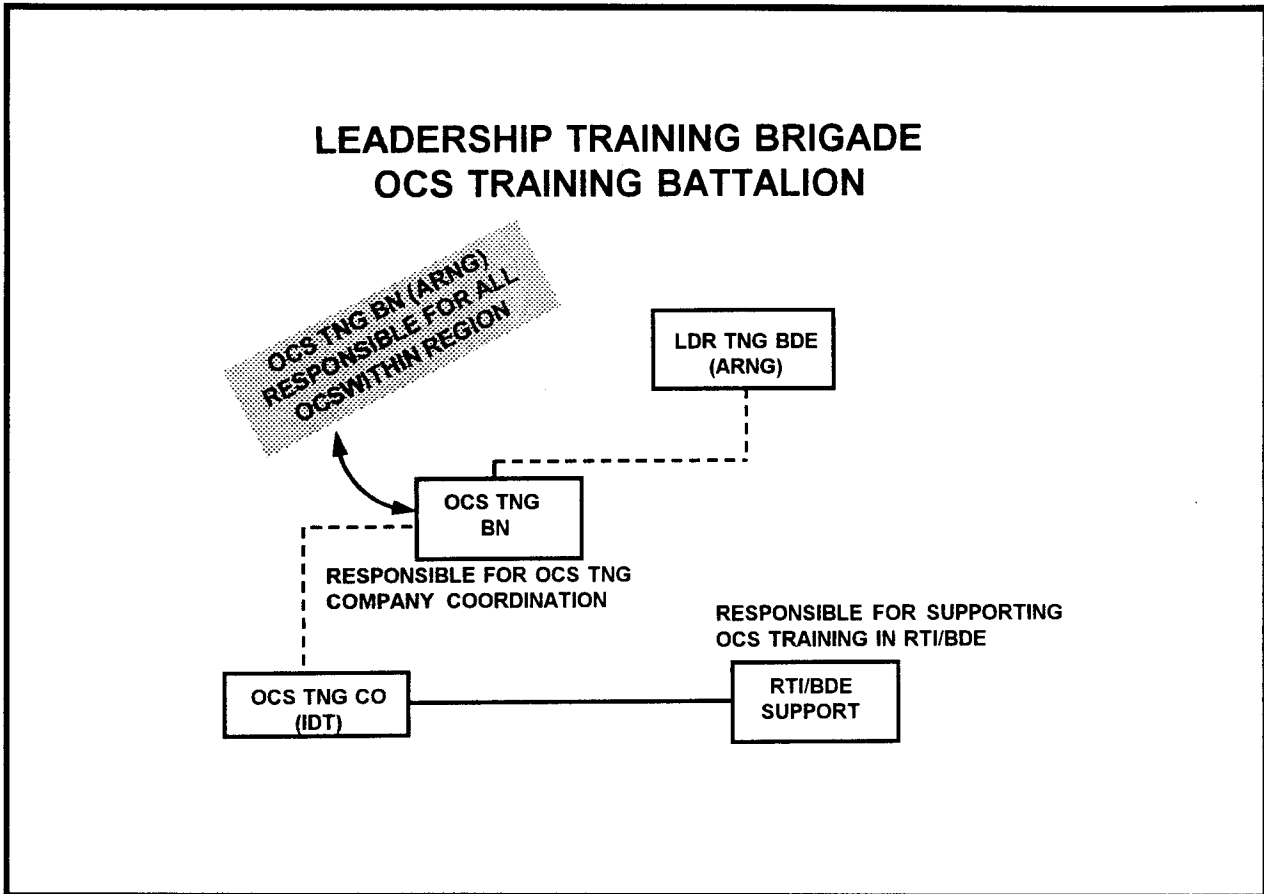

Figure 4-3. OCS Training Battalion

**4-7. Concept of the operation**

The LTB's concept of operation is the same as the CATB. (See chapter 3 for details.)

**4-8. Leadership Training Brigade locations**

- Region A** Camp Rowland, Connecticut
- Region B** Camp Fretterd, Maryland
- Region C** South Carolina Army National Guard Training Center, South Carolina
- Region D** Fort McClellan, Alabama
- Region E** Fort McCoy, Wisconsin
- Region F** Camp Beauregard, Louisiana
- Region G** Camp Murray, Washington

**4-9. NCOA and OCS Battalion locations**

- Region A**  
NCOA Battalion (USAR) Fort Dix, New Jersey  
OCS Battalion Connecticut
- Region B**  
NCOA Battalion Pennsylvania  
OCS Battalion Maryland

**Region C**

- NCOA Battalion South Carolina
- OCS Battalion South Carolina

**Region D**

- NCOA Battalion Mississippi
- OCS Battalion Alabama

**Region E**

- NCOA Battalion (USAR) Fort McCoy, Wisconsin
- OCS Battalion Minnesota

**Region F**

- NCOA Battalion Louisiana
- OCS Battalion Kansas
- R&R Battalion PEC Arkansas

**Region G**

- NCOA Battalion (USAR) Fort Lewis, Washington
- OCS Battalion Colorado

**4-10. Work groups and councils**

The LTB maintains the same membership as the CATB. (See chapter 3 for details.)

**Chapter 5  
Regional Training Institute**

**5-1. Objectives**

- a. Document the mission and organizational structure of the RTI.
- b. Provide guidance concerning the duties and responsibilities of the RTI.

**5-2. Mission**

- a. The Regional Training Institute (RTI) provides regionalized combat arms, leadership, MOS, DMOSQ Reclassification, ASI, NCOES, and GS training for the ARNG, USAR, and AC. The RTI works in conjunction with NGB, RCE, USAR DIV(IT's), and TRADOC proponent schools. The RTI monitors and coordinates academic instruction, facilities, food service and lodging for soldiers participating in training conducted at the RTI's training sites.
- b. The RTI manages training based on training requirements from NGB-ARO-TI, the ARPRINT, and the TRAP. This guidance is used to plan and program the conduct of leadership (where appropriate), and combat arms (where appropriate) individual training within the region.

**5-3. RTI Commander duties and responsibilities**

- a. Trains subordinate staff and Battalion Commanders based on current Army doctrine and accomplishes the training mission IAW AR 351-1.
- b. Randomly visits training sites to ensure training is conducted to standard. (Funding for visits is identified to NGB-ARO-TI during the annual state budget submission.)
- c. Develops and obtains approval for a RTI METL.

- d. Ensures training is realistic, safe and challenging while adhering to approved TRADOC POIs.

**5-4. Concept of the operation**

The RTI's concept of operation is the same as the CATB. (See chapter 3 for details.)

**5-5. Membership**

- a. Regional Reserve Component Pre-Structure Manning Decision Review (SMDR).
- b. Regional Training Council (RTC).

**Chapter 6  
General Studies Battalion**

**6-1. Objectives**

- a. Document the mission and organizational structure of the GS BN.
- b. Provide guidance concerning the duties and responsibilities of the GS BN.

**6-2. Mission**

The General Studies Battalion (GSB) supports CATB, LTB, and RTI training missions. The GSB exercises coordinating authority to ensure training is supported, resourced and executed. The GSB is not functionally aligned with any proponent school; but, the Leadership Training Company, Combat Arms Training Company, OCS Training Company, and Ordnance Training Company that are within the GSB are mission oriented to a specific proponent school. Most IDT missions are conducted under the responsibility of the GSB. Figure 6-1 shows the relationship of the GSB to the BDE/RTI.

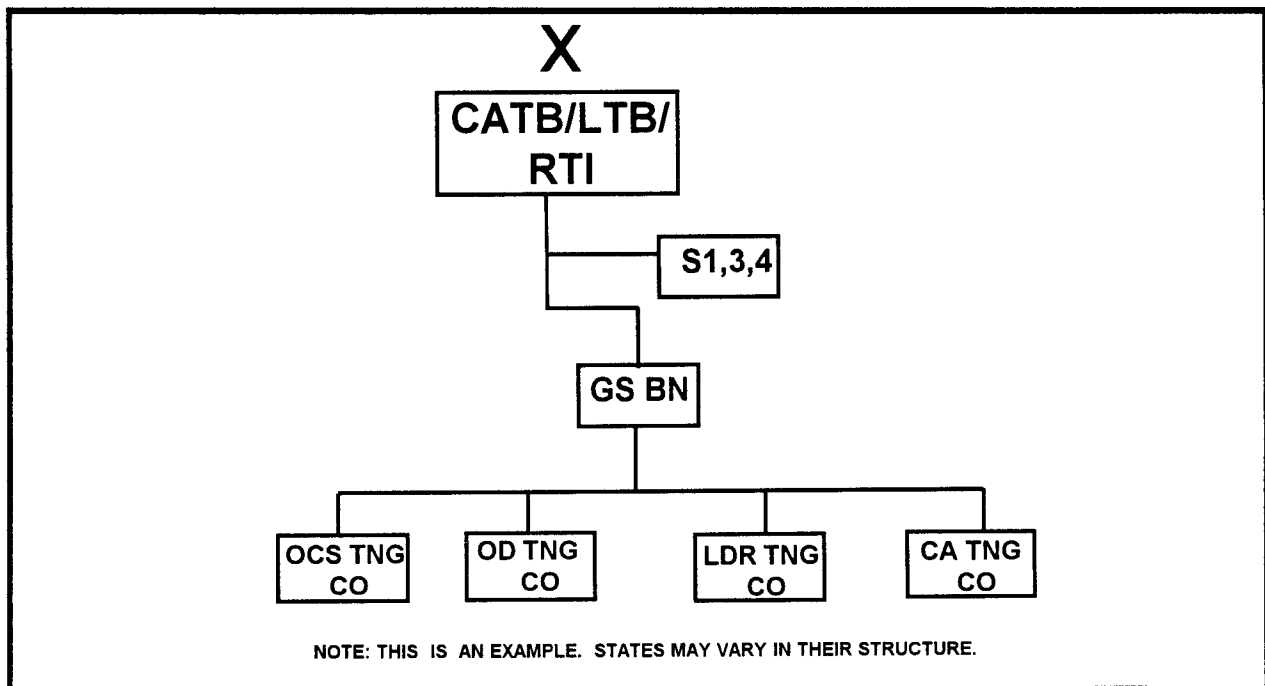

Figure 6-1. General Studies Battalion

### 6-3. General Studies Battalion functions and responsibilities

- a. Assists TASS TNG BNs in preparing training companies for accreditation.
- b. Provides instructor support.
- c. Supports all training with facilities and resources.
- d. Accountable for training companies' actions.
- e. Coordinates administrative actions for classes conducted in the state.
- f. Executes QA checks.
- g. Maintains liaison with proponent schools.
- h. Works with USAR TNG BNs.

### 6-4. GS BN Commander duties and responsibilities

- a. Trains the GS staff and Company Leadership based on current Army doctrine to accomplish the training mission IAW AR 351-1.
- b. Randomly visits training sites to ensure training is conducted to standard. (Funding for visits is identified to NGB-ARO-TI during the annual state budget submission.)
- c. Assists in development of an RTI METL.
- d. Ensures training is realistic, safe and challenging while adhering to approved TRADOC POIs.
- e. Conducts TAG directed training missions within the state.

### 6-5. General Studies Battalion relationship to TASS Training Companies in the State

Each state organizes a GSB to assist with cross-component instructor support and execution responsibility for conduct of IDT training for those companies that fall under it, e.g., OCS Tng Co, Ldr Tng Co., or Cbt Arms Tng Co. The GS Battalion supports all training requirements. Specific responsibilities are:

- a. Uses coordinating authority with the TASS TNG Bn to prepare TNG COs for evaluation and accreditation by the proponent school.
- b. Coordinates the conduct of operational, administrative, and logistical support through the S1, S3, and S4. Administration includes maintenance of instructor records within the state. The TASS TNG BNs have letter of input for NCOERs and OERs.
- c. Acts as liaison with TASS TNG BNs in other states to which it has functionally aligned training companies.
- d. Ensures that the Training Companies coordinate IDT training ammunition requirements for combat arms and leadership training with the appropriate functionally aligned TNG BN.
- e. Through the S-3, ensures that Training Companies utilize ATRRS as a management tool for courses and student loads.
- f. Receives, plans, and executes missions as directed by the RTI/BDE Commander.
- g. Coordinates with the Training Companies for METL development and action of QA issues.

### 6-6. General Studies Battalion relationship to TASS Training Battalions

The TASS TNG BNs are operationally aligned under a respective TASS TNG BDE and functionally aligned with a proponent school. The GSB is not functionally

aligned with any proponent school. It may, however, support any of the six training brigades' missions. The GSB operationally, administratively, and logistically supports the training companies and TNG BNs in an RTI. The training companies are missioned, under coordinating authority, by their functionally aligned BNs. See **Figure 6-2** for a graphic description of the role of the GSB. Letters of input are provided to the GSB by the TASS TNG BNs for those personnel involved in support of the BN's operations. **Figure 6-3** and **Figure 6-4** identify roles and missions.

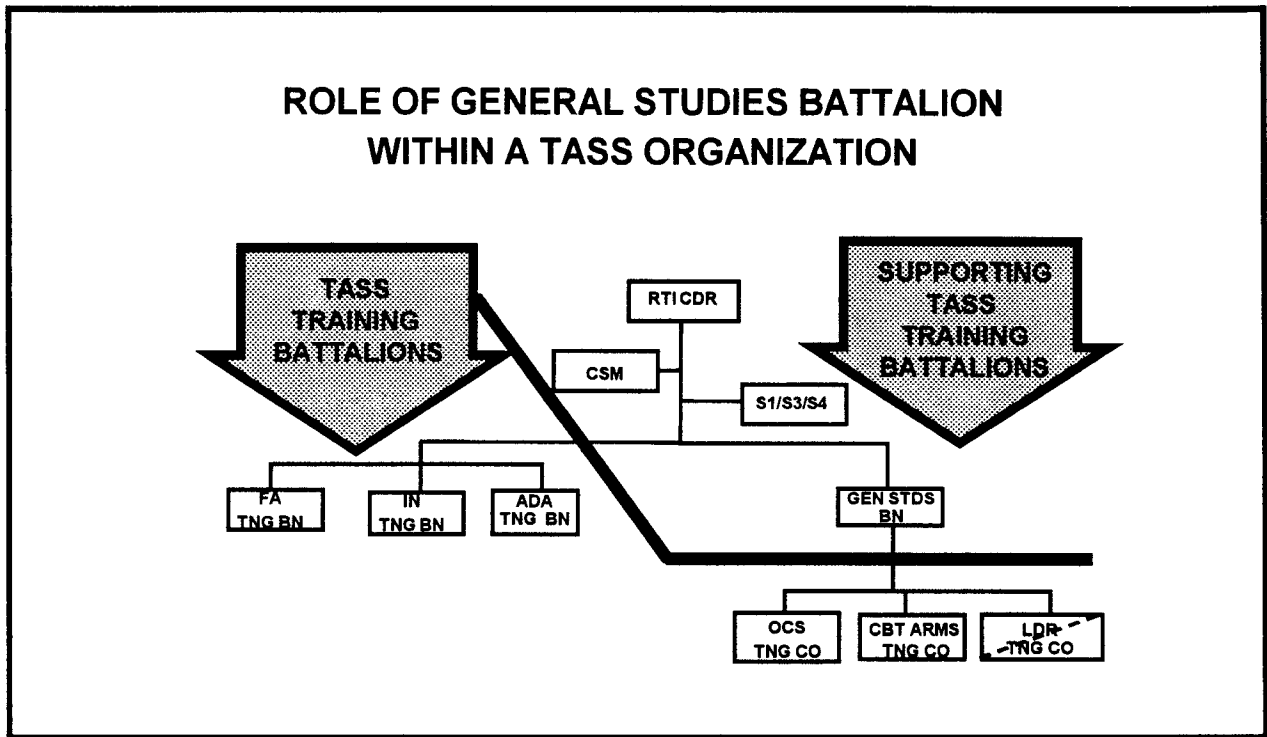

Figure 6-2. Role of GSB in TASS Organization

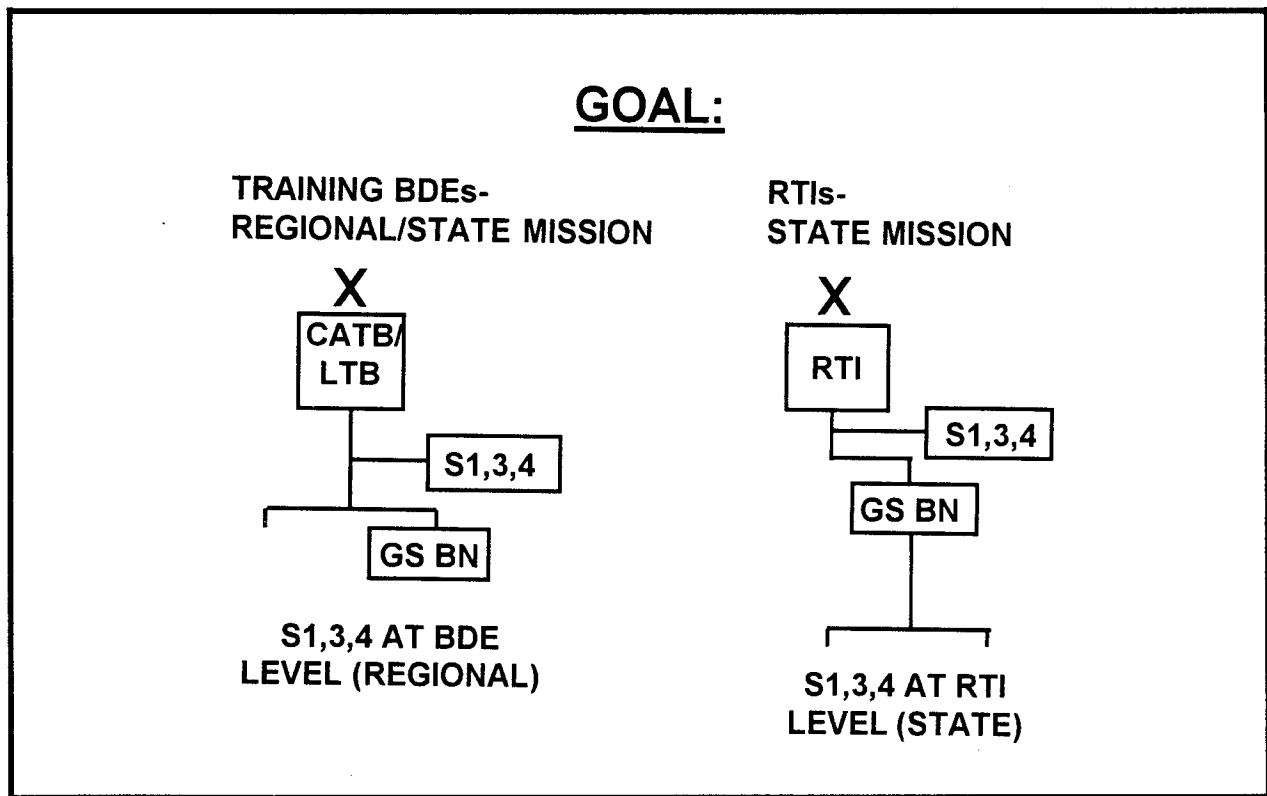

Figure 6-3. BDE/RTI Goals

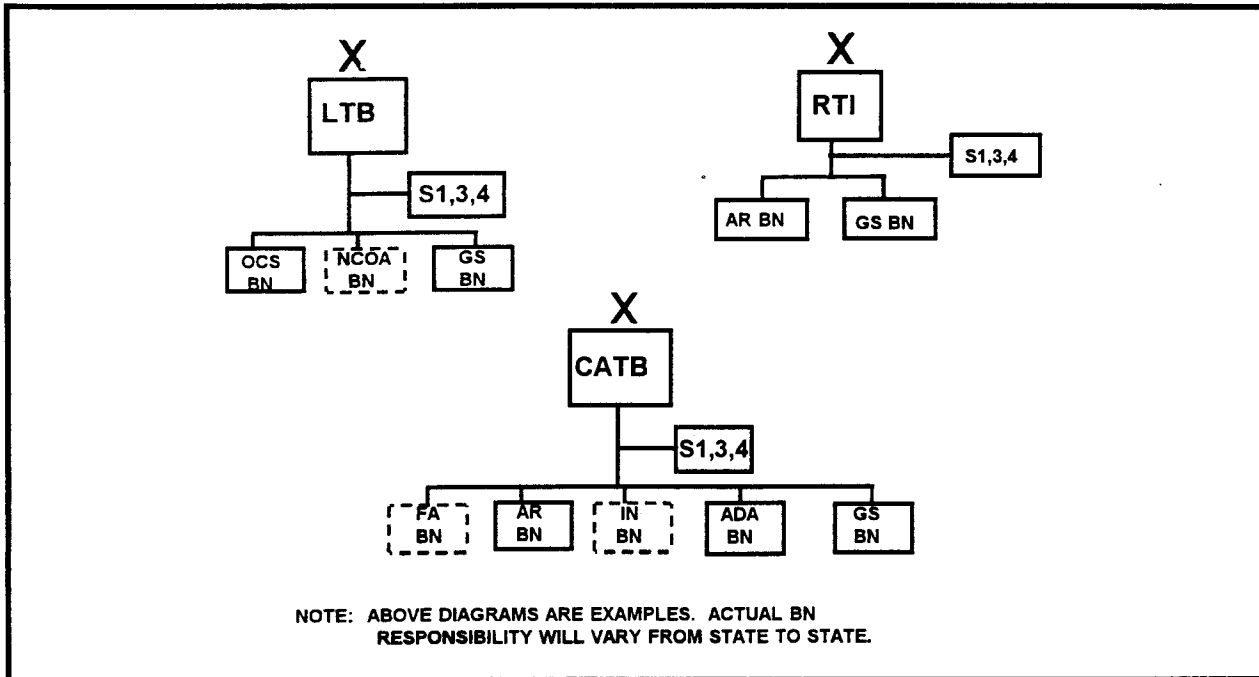

Figure 6-4. Alignment of GSB in TASS Organizations

**6-7. Leadership Training Company**

a. The Leadership Training Company executes IDT Common Leader Training (CLT) and TAG directed training missions within the state. The TNG BN, in another state, exercises coordinating authority in execution of the IDT mission. All USAR instructors that conduct IDT BNCOC and ANCOG courses are attached to

this TNG CO under the coordinating authority of the GSB for training

b. **Functional Alignment.** The Leadership Training Company is functionally aligned with the NCOA TNG BN which is functionally aligned with USASMA. (See Figure 6-5 below.)

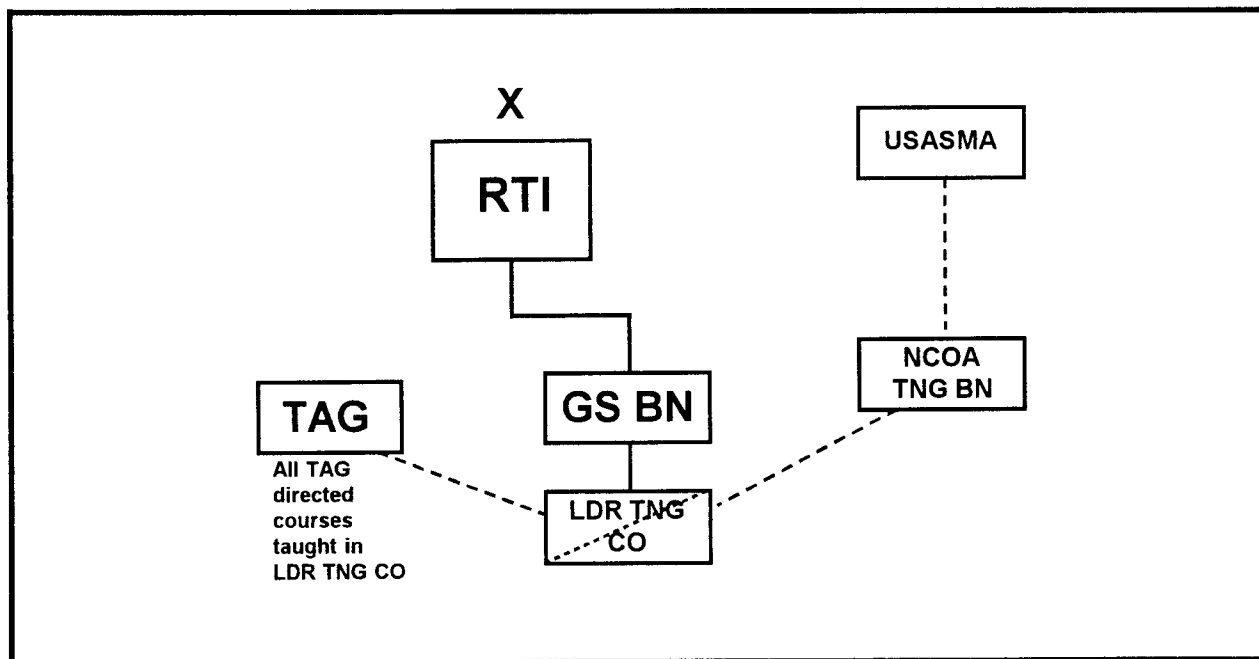

Figure 6-5. LDR TNG CO Functional Alignment



**6-8. Leadership Training Company mission**

- a. Executes all IDT leadership and TAG directed training.
- b. Supports all training requirements identified on the ARPRINT.
- c. Coordinates all training requirements through the GSB.
- d. Coordinates schedules and provides the functional TASS TNG BNs with student input and output information.
- e. Maintains conduct of training and instructor records. Historical records are kept at the TASS TNG BN. However, with BN approval, records may be kept

at the TNG CO. All records will be at the TASS BN for accreditation.

**6-9. Combat Arms Training Companies**

- a. All IDT combat arms training is conducted in the Combat Arms Training Companies. The GSB coordinates with the RTI staff for training support. NOTE: Infantry is conducted in ADT but may be split from the infantry training battalion for NCOES and DMOSQ in a CA Training Company.
- b. **Functional alignment.** Combat Arms Training Companies are functionally aligned with the training battalions. (See Figure 6-6.)

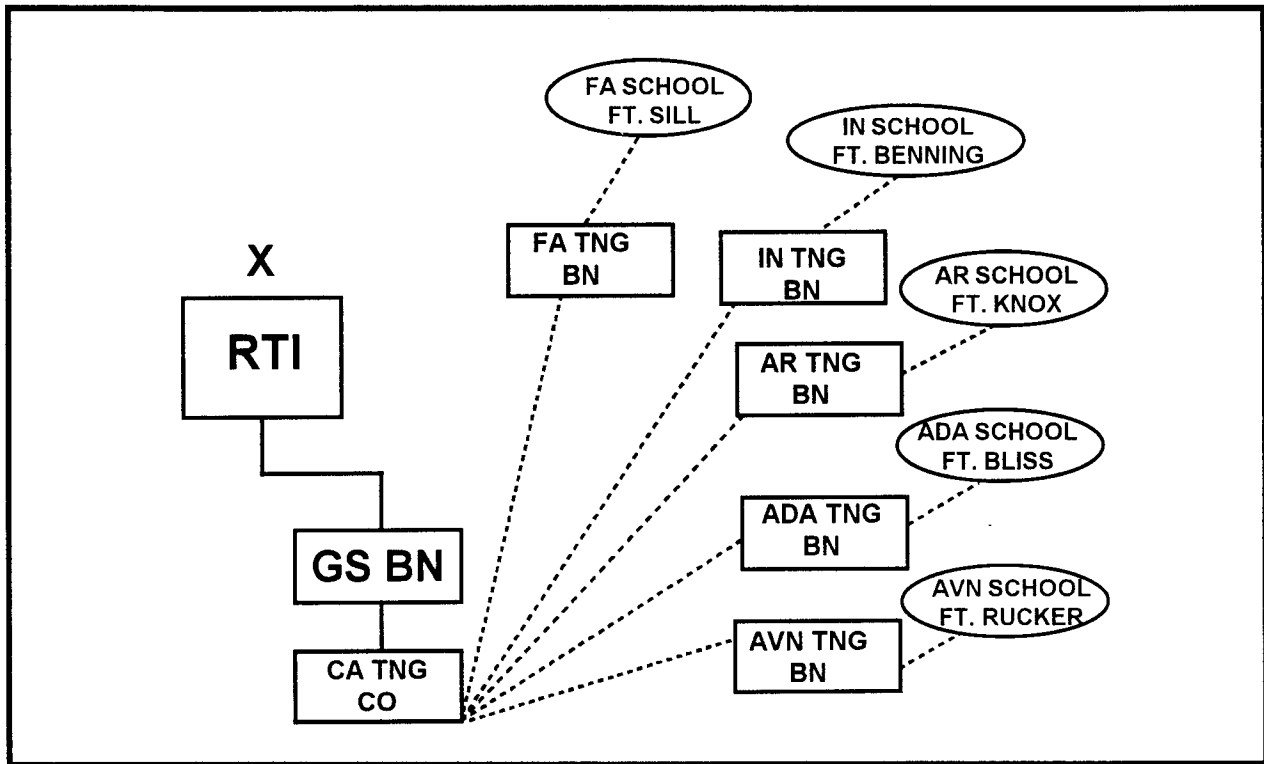

Figure 6-6. CA TNG CO Functional Alignment

**6-10. Combat Arms Training Company mission**

- a. Executes all combat arms IDT training for the state.
- b. Coordinates all combat arms IDT training through the GSB with the functional Combat Arms TNG BN. May be responsible for executing Infantry NCOES or DMOSQ ADT.
- c. Coordinates schedules and provides the functional TASS TNG BNs with student input and output information.
- d. Coordinates course graduation ceremonies with the respective functional TASS TNG BN.
- e. Maintains conduct of training and instructor records. Historical records are kept at the TASS TNG BN. However, with BN approval, records may be kept

at the TNG CO. All records must be at the TASS BN for accreditation.

**6-11. State Officer Candidate School (OCS) Training Company mission**

- a. Executes IDT OCS training IAW the Fort Benning OCS POI and as missioned by ATRRS. (See figure 6-7.)
- b. Provides command and control, administration and supervision of established policies and standards pertaining to performance, care, conduct, appearance, and safety of officer candidates.
- c. Coordinates management and support to instructors.
- d. Provides guidance and counseling to students on academic and leadership performance.

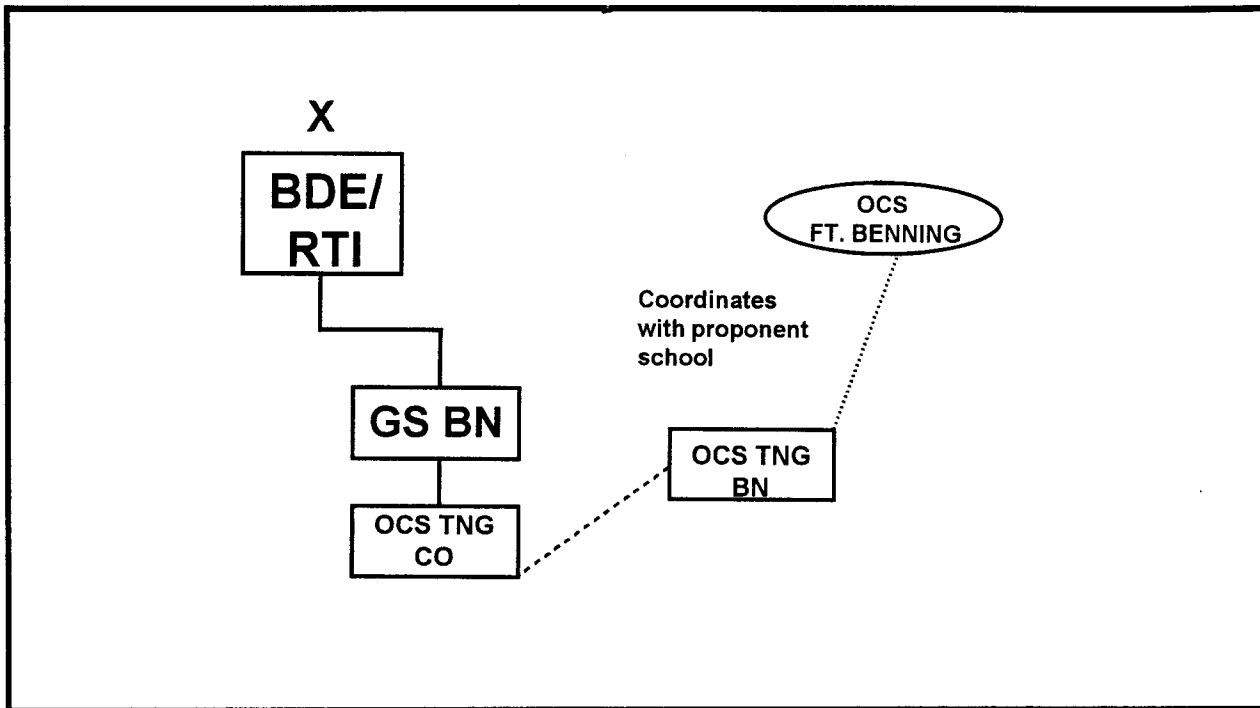

Figure 6-7. OCS TNG CO Functional Alignment

**6-12. Ordnance Training Company mission**  
**a.** Execute the NGB approved training mission IAW Ordnance School POI. (See Figure 6-8.)

**b.** Coordinate training schedules and provide the Ordnance TNG BN with information concerning graduation data.

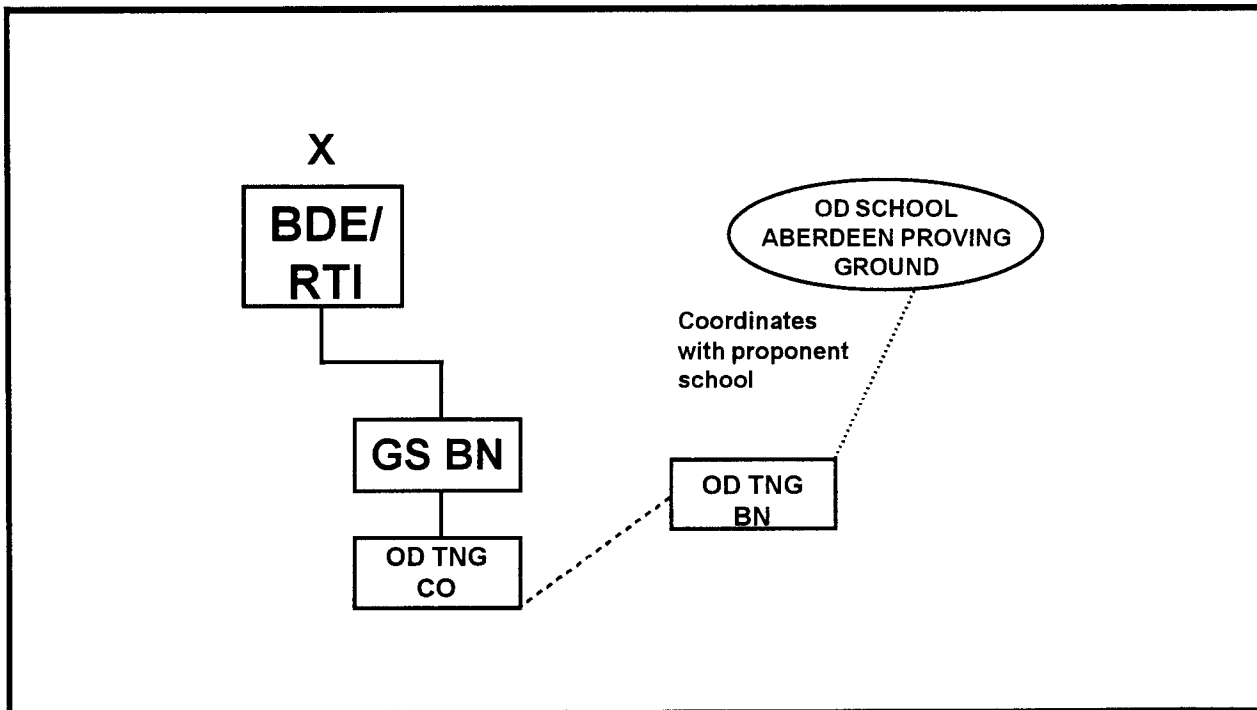

Figure 6-8. OD TNG CO Functional Alignment

**Chapter 7  
Engineer Training Battalion (ARNG)**

**7-1. Objectives**

- a. Document the mission and organizational structure of the EN TNG BN.
- b. Provide guidance concerning the duties and responsibilities of the EN TNG BN.

**7-2. Mission**

- a. The EN TNG BN provides regionalized Engineer, Leadership, MOS, DMOSQ Reclassification, ASI, and NCOES training for the ARNG, USAR, and AC. It also performs regionalized management and QA oversight for all EN training. The EN TNG BN works in conjunction with the RTI, NGB, the RCE, the USAR DIV(IT), the Combat Support (CS) TNG BDE, and TRADOC proponent school. The RTI monitors and coordinates academic instruction, facilities, food service and lodging for soldiers participating in training conducted at the RTI's training sites.
- b. The EN TNG BN uses coordinating authority to issue guidance, and to plan/program the conduct of engineer individual training within the region.

**7-3. EN TNG BN Commander duties and responsibilities**

- a. Executes the EN CMF training mission as identified in ATRRS IAW with Ft Leonard Wood Engineer School POI. (See Figure 7-1.)

- b. Establishes and maintains a working relationship with affiliated TRADOC proponent school Directorate of Evaluation and Standardization (DOES) or equivalent. This task is accomplished by the assigned Title XI soldiers and points of contact designated in each TNG BN.
- c. Develops a TNG BN METL supporting the RTI mission and addresses specific QA within the EN TNG BN.
- d. Submits requests for POI waiver requirements through the RTI to the approving authority. The TNG BN may submit a request for waiver directly to the proponent school, but a copy furnished (CF) must be sent to the RTI, the CS TNG BDE, the RCE, and NGB-ARO-TI.
- e. Provides copies of all training schedules to the RTI which in turn will furnish them to the RCE and CS TNG BDE.
- f. Coordinates RCE evaluation visits through the CS TNG BDE.
- g. Conducts instructor evaluations in accordance with TR 350-70 and established standards.
- h. Maintains records for personnel actions and student graduation at the respective TNG BN. This authority may be delegated to the instructional location (school code), but the TNG BN maintains responsibility for all records during accreditation evaluations.

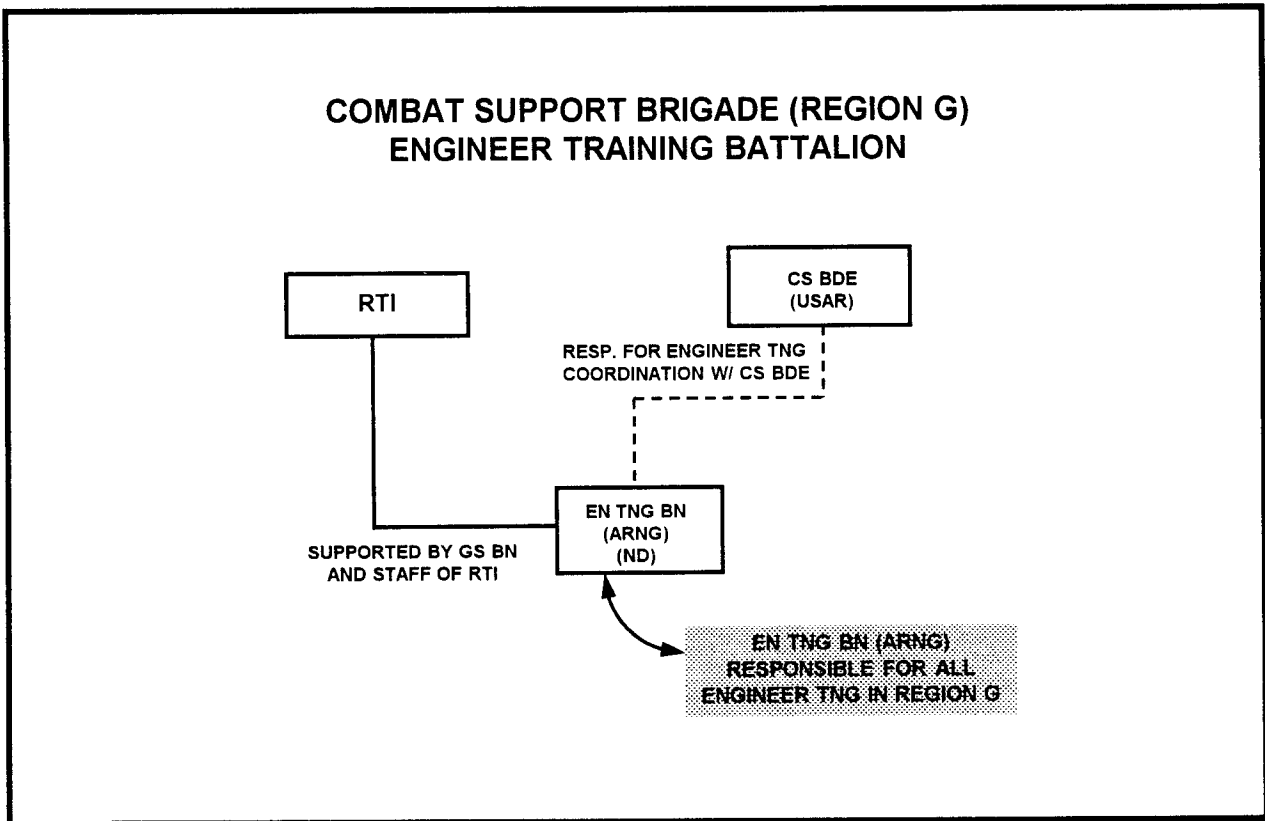

Figure 7-1. EN TNG BN Functional Alignment

**Chapter 8  
Ordnance Training Battalion**

**8-1. Objectives**

- a. Document the mission and organizational structure of the OD TNG BN.
- b. Provide guidance concerning the duties and responsibilities of the OD TNG BN.

**8-2. Mission**

a. The OD TNG BN provides regionalized Ordnance, Leadership, MOS, DMOSQ Reclassification, ASI, and NCOES training for the ARNG, USAR, and AC. The OD TNG BN also performs regionalized management and QA oversight for all OD TNG. The OD TNG BNs work in conjunction with the RTI, NGB, RCE, USAR DIV(IT's), CSS TNG BDE, and TRADOC proponent school. The RTI monitors and coordinates academic instruction, facilities, food service and lodging for soldiers participating in training conducted at the RTI's training sites.

b. The OD TNG BN uses coordinating authority to issue guidance, and to plan/program the conduct of ordnance individual training within the region.

**8-3. OD TNG BN Commander duties and responsibilities**

- a. The OD TNG BN's CDR has the same duties and responsibilities (see Chapter 7) as the EN TNG BN CDR with the exception of paragraph b.
- b. Executes the training mission as identified in ATRRS in the OD CMF IAW OD School POI.

**8-4. TASS Ordnance relationships**

Each RTI has command and control over their OD TNG BNs and COs. The CSS BDE has coordinating authority over the OD TNG BN, which has coordinating authority of the company located in other states. (See Figure 8-1.)

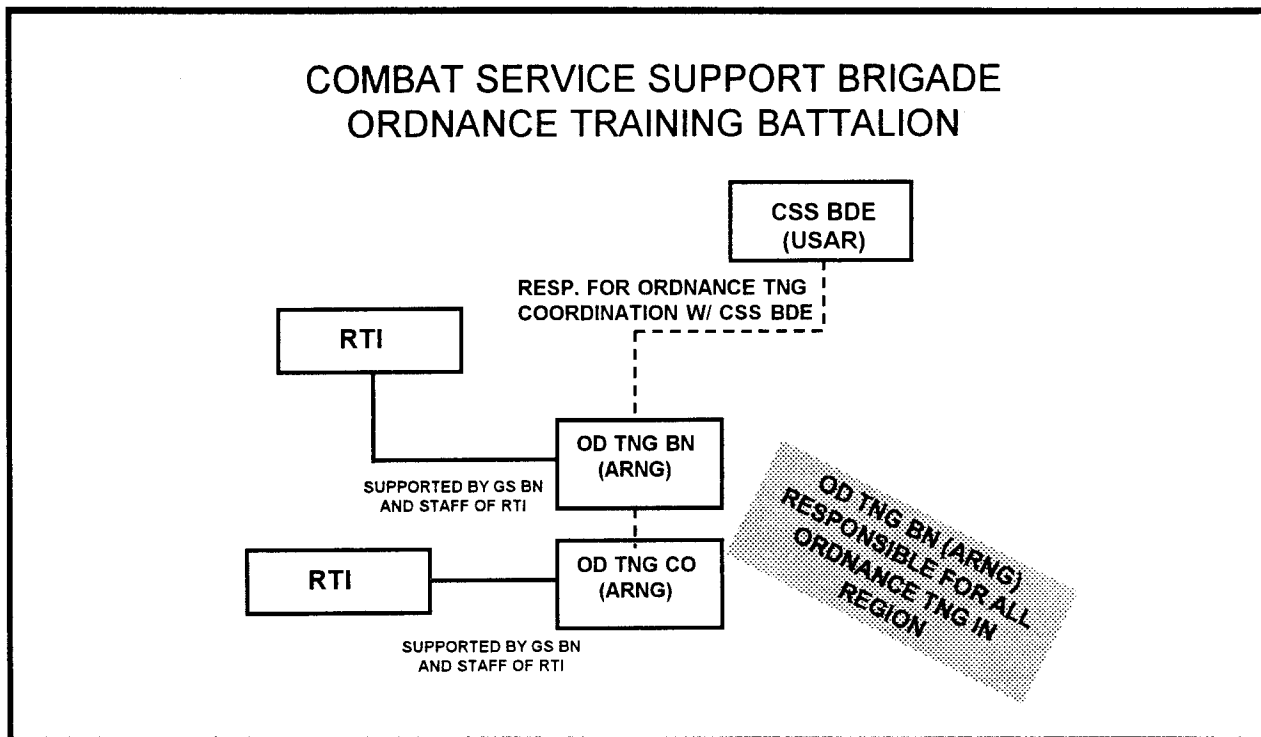

**Figure 8-1. OD TNG BN Functional Alignment**

**8-5. Locations of Ordnance Battalions**

- Region C** Fort Stewart, Georgia
- Region D** Camp Shelby, Mississippi
- Region F** Jefferson City, Missouri
- Region G** Gowen Field, Idaho

**8-6. Locations of Ordnance Companies**

- Region A** New Jersey
- Region C** North Carolina, Georgia, Florida
- Region D** Mississippi
- Region E** Minnesota, Michigan
- Region F** Iowa, Missouri, Kansas
- Region G** California, Idaho, Hawaii

## Chapter 9 Recruiting and Retention Battalion

### 9-1. Objectives

a. Document the mission and organizational structure of the Recruiting and Retention Battalion.

b. Provide guidance concerning the duties and responsibilities of the Recruiting and Retention Battalion.

### 9-2. Mission

a. The Recruiting and Retention School located at the Professional Education Center (PEC) is now the Region F Recruiting and Retention Training Battalion. The Recruiting and Retention Training Battalion retains the School Code of the previous Recruiting and Retention School at PEC. The Training Battalion is to participate in the Region F Pre-Structure Manning Decision Review as a part of the TASS organization for the region.

b. The United States Army Soldier Support Institute (USASSI) at Fort Jackson and the United States Army Sergeants Major Academy (USASMA), at Fort Bliss ensure functional alignment, instructor certification, current courseware development, and accreditation occur according to the Training and Doctrine Command (TRADOC) regulations. All TRADOC POI recruiting and retention training missions are functionally aligned with the USASSI. The Advanced Non-Commissioned Officer Course (ANCOC) courses have dual alignment with USASSI for MOS specific tasks and USASMA for non-MOS specific (common core) tasks.

c. The ANCOC accreditation by USASMA will be during the Non-Commissioned Officer Academy (NCOA) Training Battalion accreditation. The accreditation cycle for the USASSI will be determined between the Training Battalion and the proponent school. The Recruiting and Retention Training Battalion is to copy furnish the Leadership Training Brigade in Region F with accreditation and any other significant information.

## Chapter 10 Aviation

### 10-1. Mission statement

The TASS AV TNG BNs are responsible for Aviation MOSQ, NCOES, ASI, flight instructor training, aviation medical training, cargo flight training, aviation maintenance training, MOSQ requalification, and other training as directed by NGB Aviation Directorate.

### 10-2. Concept of operation

a. The NGB, through the Army Aviation Training Site (AATS) coordinator located at National Guard Bureau Aviation and Safety Directorate (NGB-AVN), provides an operational alignment that coordinates the planning, training, resourcing and evaluation process for the Army Aviation Training Site Schools. The AATS coordinator also facilitates Army Aviation Training by providing coordination and continuity between the AATS and other pertinent TASS organizations.

b. The AATS coordinator interacts with the following agencies:

(1) **NGB-AVN.** AATS coordinator reports directly to NGB-AVN and directs AATS mission guidance based on identified training requirements. NGB-AVN has responsibility for funding considerations for the training sites.

(2) **State Adjutant General.** The AATS coordinator coordinates with the TAG for all personnel, administrative, logistical, and facilities support.

(3) **Other agencies.**

(a) **General.** The AATS coordinator establishes relationships and resolves issues with other TASS organizations.

(b) **Proponent School (USAAVNC).** The AATS Coordinator establishes an operational link between the training site and proponent school. USAAVNC establishes a Division of Evaluation and Standardization (DES) presence at each of the AATS. The DES section will be documented on the NGB-AVN TDA. The NGB-AVN provides Title 10 soldiers to fill these positions at the AATS.

1. The AATS Coordinator participates in the approval process of all aviation training development. All Army aviation training taught at the AATS is reviewed by the AATS coordinator.

2. The AATS Coordinator interacts with the AATS headquarters on all aviation training site issues between it and USAAVNC to include POI development.

(c) The AATS Coordinator performs the following functions:

1. Assists in synchronized planning for AATS aviation operations and training. Establishes and coordinates resource requirements in conjunction with NGB-AVN, NGB-ARO-TI (ATTRS), State TAG and other contributing agencies.

2. Coordinates aviation related issues between the aviation training site and the proponent school. Reviews and obtains approval of course POI.

3. In coordination with the AVN LNO, NGB-ARO-TI (ATTRS quota manager), monitors aviation training program execution to include training seat fill rates, no show, turn backs, non-compliance with prerequisites, and other training distracters.

4. Assists in development, and approves Standing Operating Procedures (SOP).

5. Participates with NGB-ARO-TI in the TRAP, TACITS, MEGATRIP and SMDR processes as required.

6. Monitors management of funding accounts affecting AATS training, operations and maintenance through internal organizational means and representation in each State's USPF&O.

c. The Aviation Training Battalions (ATB) have a functional alignment with the Aviation proponent school located at Ft. Rucker, Alabama. The ATBs are required to follow all policies and procedures IAW Aviation POIs and coordinate with the AATS Coordinator as required by this section.

d. See Figure 10-1 and Figure 10-2 for graphs.

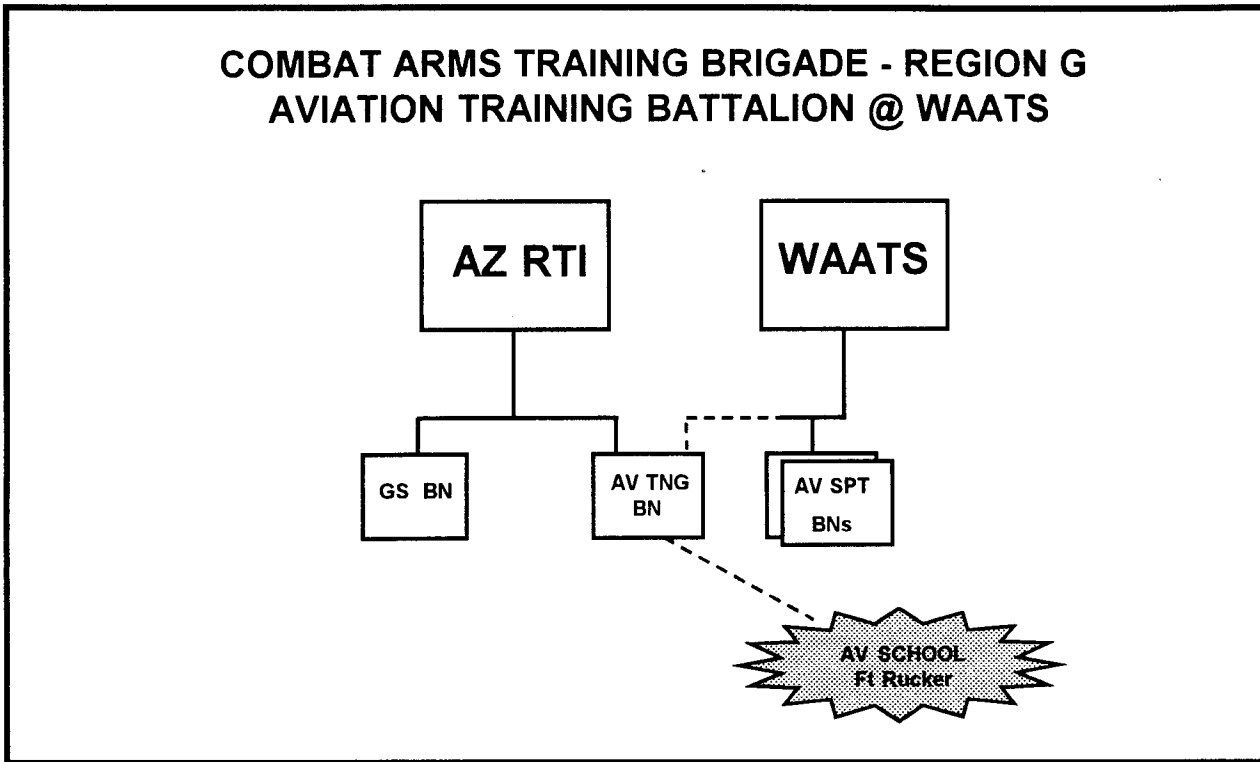

Figure 10-1. AV TNG BN (Region G) Functional Alignment

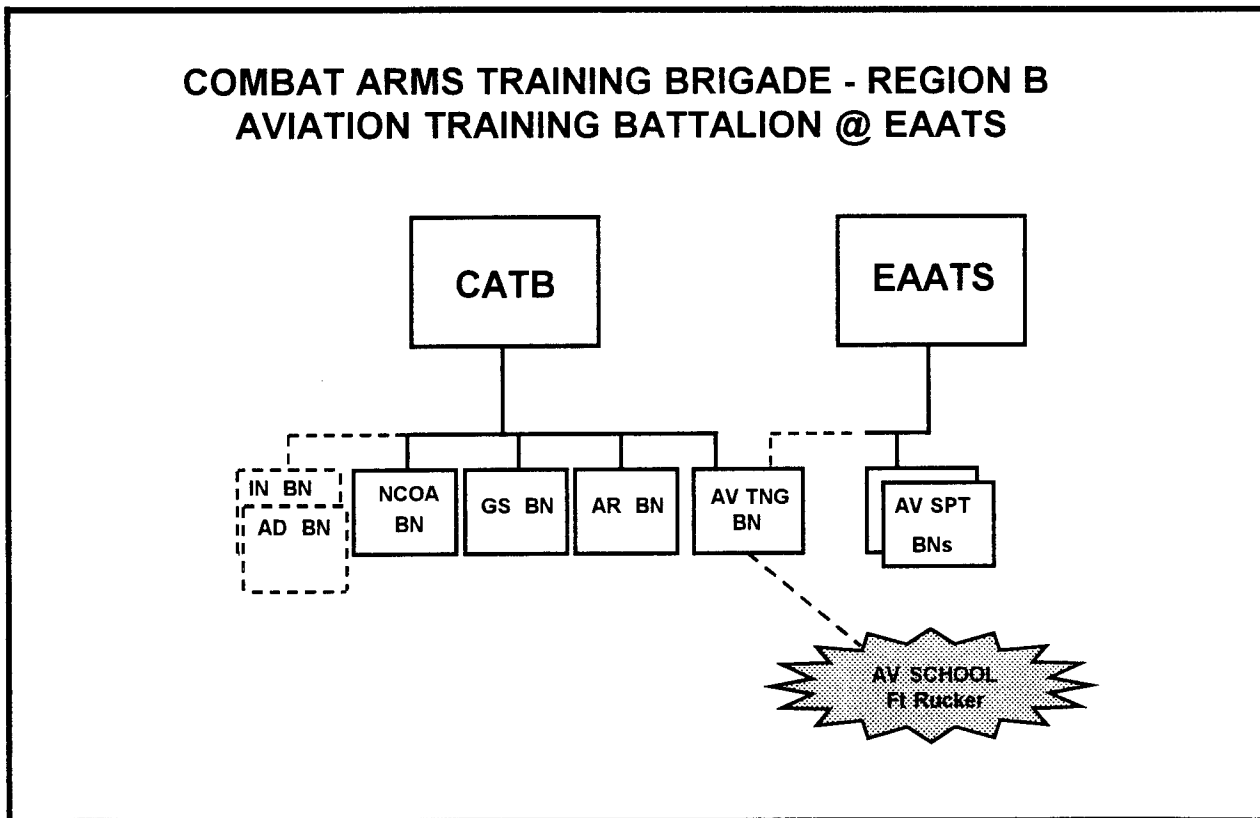

Figure 10-2. AV TNG BN (Region B) Functional Alignment

## Chapter 11 Individual Training Branch (NGB-ARO-TI)

### 11-1. Purpose

Identification and clarification of the TASS and ATRRS initiatives that encompass the MISSION of the Individual Training Branch (NGB-ARO-TI) of the NGB Training Directorate.

### 11-2. Vision

Provide training and skill validation opportunities to ensure that unit individual training objectives are met in the most efficient and economical manner.

### 11-3. Mission

- a. Resources individual training for the ARNG.
- b. Coordinates management of all ARNG quotas in AC, DoD, and RC.
- c. Manages ARNG portion of the ATRRS Life Cycle IAW AR 350-10.
- d. Staffs individual training programs and policies with DA, OCAR, USARC, TRADOC, FORSCOM and subordinate commands in the ARNG.
- e. Develops regulations and policies for the management and conduct of ARNG individual training.

### 11-4. Objectives

- a. Full execution of TASS (complete accreditation cycle).
- b. Full implementation of ATRRS.
- c. Manage school quotas and resources in ATRRS by readiness levels/priority units.
- d. Leverage appropriate emerging training technologies.
- e. Educate ATRRS users through interactive workshops.
- f. Coordinate effectively with ARNG Liaison at the TRADOC Proponent School.

### 11-5. Schools structure development

- a. LTB and CATB with appropriate TASS TNG BNs were developed in each TASS Region within the ARNG.
- b. RTIs were developed in each state that does not have a TASS TNG BDE.
- c. The Regional NCO Academies were rolled into the TASS structure with the State Military Academy to become an RTI or TASS TNG BDE.

### 11-6. Resourcing

- a. **Priority Requirements:**
  - (1) Initial Skills Acquisition.
  - (2) Career Development.
  - (3) Refresher/Proficiency.
- b. **Priority of Effort.**
  - (1) Dollars identified to resource training.
  - (2) Priority Units identified for schools funding.

### 11-7. Requirements (Reserve Component ATRRS Life Cycle Management) - ATRRS

- a. Policy (AR 350-10).
  - (1) Management Overview of training.
  - (2) Resourcing training requirements.
  - (3) Arbitration to conduct valid training.

### b. Management of the following:

- (1) TACITS.
- (2) SMDR.
- (3) TRAP.
- (4) Requirements validated .
- (5) School Missioning - Individual Training Branch (NGB-ARO-TI).

### c. Execution:

- (1) **Schools.**
  - (a) Scheduling.
  - (b) TRAP.
  - (c) Executive Program.
  - (d) Input/Output.
- (2) **Quota Managers.**
  - (a) Requirements.
  - (b) TRAP.
  - (c) Reservations.

### 11-8. Intermediate goals

- a. FY97: Full TASS Implementation to include the Training Management Life Cycle.
- b. FY98: ATRRS down to lowest practical level.
- c. Automation to support ATRRS implementation.
- d. Further alignment of schools to meet valid training requirements.
- e. Annual ARNG TASS organization meeting during TOESC.
- f. Tie school requirements to the POM.
- g. Reliable requirement data and quota model (Cost Benefit Model), as part of ARNG Individual Training Resource Model (ITRM).

### 11-9. Noncommissioned Officer Education System (NCOES)

- a. **Objective.** The objective of NCOES is to prepare NCOs to lead and train soldiers who work and fight under their supervision.
- b. **Purpose.** The NCOES courses provide NCOs with progressive and sequential leader, technical and tactical task training relevant to duties, responsibilities and missions they will perform as leaders after graduation. Training builds on existing skills, knowledge, behaviors and experience. NCOES is linked to the enlisted personnel management system through the Select Train Promote Assign in accordance with Chapter 11, NGR 600-200. NCOES consists of four levels:
  - (1) Primary Leadership Development Course (PLDC).
  - (2) Basic NCO Course (BNCOC).
  - (3) Advanced NCO Course (ANCOC).
  - (4) Senior level/U.S. Army Sergeants Major Academy Course (USASMC).

### 11-10. Officer Education System (OES)

- a. **Purpose.** The ARNG is responsible for the education of its officers at all levels.
- b. **Objective.** To provide the ARNG an education system that will help maintain and develop a professionally trained Officer Corps.
- c. **Scope.** The ARNG is resourced with quotas that allows the ARNG to offer officer education at all levels. Career development is in accordance with AR

611-101. The following is a list of courses that are available to ARNG officers:

- (1) Officer Basic Course (OBC).
- (2) Officer Advance Course (OAC).
- (3) Combined Arms and Services Staff School (CAS3).
- (4) Intermediate College Level Courses.
- (5) Senior Services College Level Courses.

Attendance in the OBC is resident only. Attendance in the remaining courses may be in a resident phase, RC Resident phase, or a combination of correspondence courses with a resident phase to graduate.

#### 11-11. Warrant Officer Education System (WOES)

**a. Purpose.** The ARNG is responsible for the education of Warrant Officers at all levels.

**b. Objective.** To provide the ARNG an education system that will help maintain and develop a professionally trained Warrant Officer corps.

**c. Scope.** The ARNG is resourced with quotas that allows the ARNG to offer Warrant Officer education at all levels. Career development is in accordance with AR 611-101. The following is a list of courses that is inclusive in the ARNG WOES:

- (1) Warrant Officer Candidate School (WOCS).
- (2) Warrant Officer Basic Course (WOBC).
- (3) Warrant Officer Advance Course (WOAC).
- (4) Warrant Officer Staff Course (WOSC).
- (5) Warrant Officer Senior Staff Course (WOSSC).

Except for WOCS, attendance in these courses may be in a resident phase, RC Resident phase, or a combination of correspondence courses with a resident phase to graduate.

## Chapter 12 Training Management

### 12-1. Individual Training Management Life Cycle

**a.** The Total Army Centralized Individual Training Solicitation (TACITS) and training requirements generation process within the Individual Training Management cycle is the methodology for deriving regional training requirements input into the SMDR. The ARPRINT is a product of the SMDR and missions the school system. The training brigades, battalions and training companies review the training missions and input any facility, equipment and instructor constraints that will negatively effect execution of the ARPRINT mission. Class schedules are posted. Input into the TRAP defines those actual training requirements within the state and regional boundaries. As the school mission is further refined, quota allocations by NGB results in training seats for a scheduled course. The course is conducted with student input data being posted at the beginning and student graduation status being posted upon completion. The Program Execution Analysis is conducted on the ARPRINT missions. From the analysis, modifications to future school missions are rec-

ommended. Input of TACITS energizes the Training Management cycle for the initiation of Program Objective Memorandum (POM) year planning and a relook at the budget year as the cycle continues. **Figure 12-1** gives an overview of the Training Management Life Cycle

**b. Input and graduation update.** Training Battalions and companies must post student status through ATRRS at the beginning of a class and post the student's graduation status at the completion of the class.



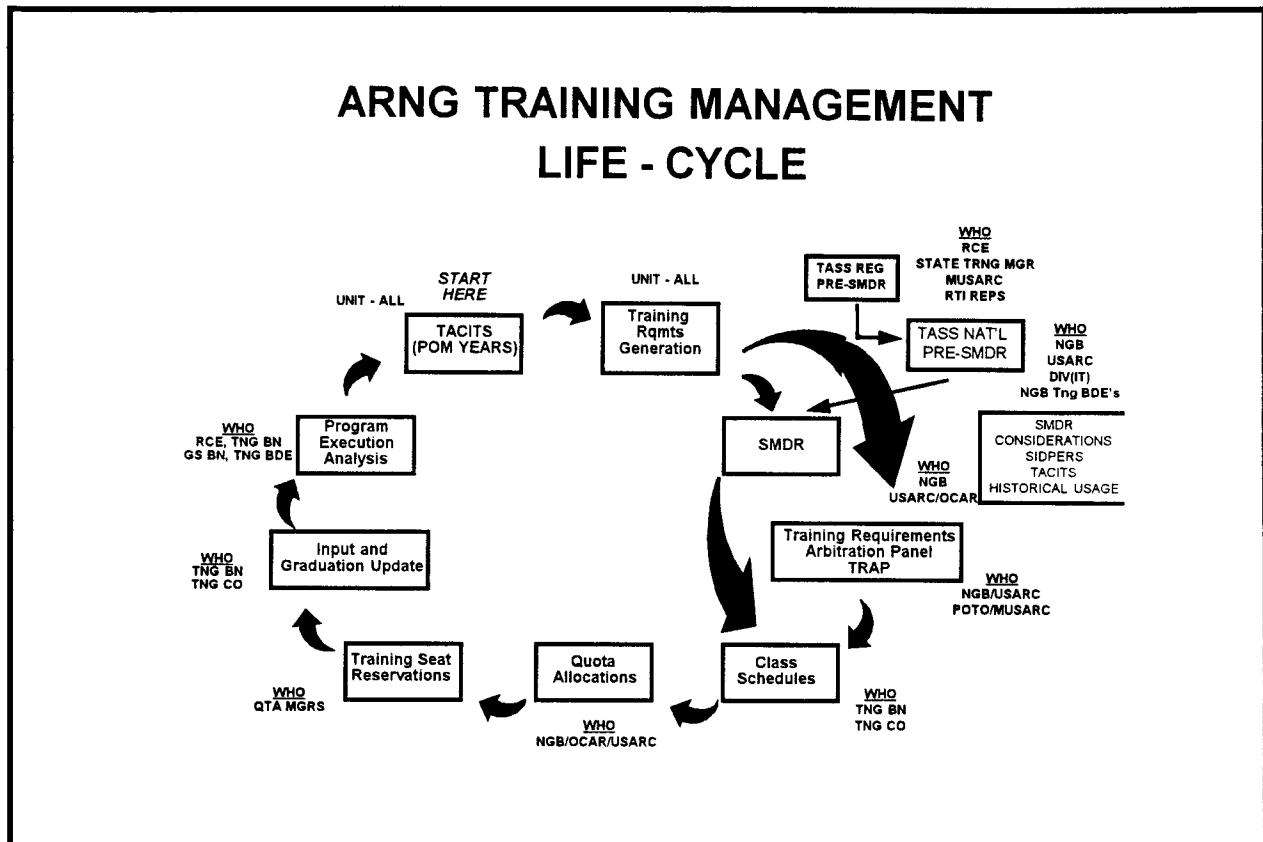

Figure 12-1. ARNG Training Management Life Cycle

### 12-2. Total Army Centralized Individual Training Solicitation (TACITS)

TACITS is the process by which Quota Managers submit their individual training requirements by fiscal year for the POM years. The requirements are submitted by Quota Source code, UIC and component code. Preliminary solicitation is in August of each year and solicitations for new courses occur in April. ATRRS screens that are used for data input in TACITS are the (UD) screen (to update the directory of units) and the (US) screen (to input training requirements). The POC identifier of the US screen (A) identifies Active Component courses. The (UM) screen is used by NGB and USARC to input, change, and review training requirements. Units then run their reports from TSO to check what they solicited in TACITS.

### 12-3. Training requirements generation

Training Requirements Generation is the time-frame in which units, TNG BNs, and TNG COs review training requirements and input any facility, equipment, and instructor constraints that will negatively impact execution of TACITS requirements. See Figure 12-1 for the training management life cycle.

### 12-4. Structure Manning Decision Review (SMDR)

The SMDR is a process designed to validate the requirements entered on TACITS, reconcile them

against the constraints entered by ARNG school battalions and training companies, and develop them into an affordable, acceptable, and executable training program. The SMDR process is conducted in three phases:

**a. Regional pre-SMDR:** This phase is conducted in each region and hosted by the RCE with representatives from the DIV(IT)s, BDEs, State Quota Managers and RTIs. Validation of regional training requirements is the primary objective. Regional schools' capabilities are identified in order to determine if those capabilities can satisfy regional training requirements. If requirements are greater than capabilities, the course is flagged as constrained. Constraints are first addressed at this level for resolution. Regional Pre-SMDRs will be conducted annually in July or August.

**b. National pre-SMDR:** This phase is conducted by NGB / USARC, attendees include representatives from each RCE, TASS BDE and DIV(IT). Primary focus is on those courses that were flagged during the regional processes. During the constraint resolution process at the National Pre-SMDR, all regions will be evaluated in order to determine if requirements can be satisfied. This phase builds on the efforts of the Regional Pre-SMDR. It is usually conducted in September.

**c. SMDR:** This phase is conducted by personnel from NGB, OCAR, USARC, and DA who are responsible for determination of what agency will pay for train-

ing and constraints effecting training requirements. This phase is conducted in the October - November timeframe. The SMDR results are forwarded to the Counsel of Colonels (CoC) for review and resolution of problems. Once completed, recommendations from the CoC are forwarded to the General Officer Steering Committee (GOSC) for action on those issues that cannot be resolved. The SMDR data approved at the GOSC level is then published each July, as the ARPRINT. The ARPRINT is the mission document for all ARNG training battalions and training companies.

**d. Training Requirements Arbitration Panel (TRAP):** The TRAP is the process by which MACOM Quota Managers and Sub-Quota Managers can request changes to the current ARPRINT. Training battalions and training companies determine if they can support additional requirements based on requested changes. Agencies involved are: NGB, USARC, POTOs, ARCOMs, and MACOMs.

**e. Class schedules:** Beginning each July, ARNG school battalions and training companies have 45 days to input class schedules for POM-1, which support the ARPRINT projections two years out.

**f. Quota allocations:** Quota Allocations are determined each September. Once the ARPRINT is approved, training quotas are allocated automatically. Quota Allocations are distributed on a fair share basis supported by requirements input in TACITS and approved by the ARPRINT. Components are: NGB, OCAR, and USARC.

**g. Training seat reservations:** Quota Managers who have received quotas during the Quota Allocation process can schedule personnel into a training seat for a scheduled course. Quota Managers can Sub-Allocate down one level. Training seats are reserved during the Budget and Execution years.

**h. Input and graduation update:** TNG BNs and TNG COs must post student status at the beginning of a class and post the student's graduation status upon completion of the class.

**i. Program execution analysis:** Data used in the Program Execution Analysis (PEA) process is comprised of both Training Attrition Rates and No-Show rates. The Training Attrition Rate is a percentage of students that do not successfully complete the course. The No-Show rate is the percentage of students with reservations that do not report. These numbers are used to validate future quota requests in TACITS. The RCE, GSB, TNG BN, and TNG BDE are involved in the analysis.

#### 12-5. School codes

**a. General.** School Codes are assigned to the actual location where training is conducted. This is associated with the ATRRS identifier and provides a funding site for the Individual Training Branch (NGB-ARO-TI) to disperse funds.

**b. Distribution of funds.** As a minimum, each state will have a School Code (SC) for the RTI, LTB, or CATB. All training that occurs within the state under the organization of the TNG BN or TNG CO is funded through this SC. The funds are sent from the Individual Training Branch to the POTO of the state who distributes funds to execute training.

**c. Records.** All training records for the conduct of training are to be maintained at the SC. This is the actual teaching location and is the appropriate location for current and historical records. Instructor records are also available for inspection at the SC. Records will be provided to the TASS BN for accreditation.

**d. Geographical.** The SC isolates a given geographical area for conduct of training. This is especially important for the conduct of IDT.

#### 12-6. Training outside functional alignment

If the USAR cannot execute its regional mission, the following steps must be executed to accomplish regional ARNG training requirements:

**a.** The BDE/RTI obtains written documentation from the USAR that the USAR is unable to execute its regional mission. As a minimum, this documentation should include the specific reasons why the USAR is unable to accomplish the mission.

**b.** The BDE/RTI will forward this memo, with endorsement, to the NGB-ARO-TI TASS team.

**c.** The TASS team will coordinate with the NGB-ARO-TI NCOES Team Chief.

**d.** The NGB-ARO-TI NCOES Team Chief will coordinate with the USARC for determination of execution and resources available.

**e.** The final decision for execution rests with NGB-ARO-T (Chief, Training Division).

**f.** The originating BDE/RTI will be notified through the respective POTO.

### Chapter 13

#### Resourcing TASS and Staff Responsibilities

##### 13-1. Objectives

To provide guidance for the TASS schoolhouses concerning support requirements.

##### 13-2. Resources

**a. Facilities.** The BDEs and RTIs will continue to occupy and use existing facilities.

**b. Equipment.** Equipment documented on the previous State Military Academy (SMA) Table of Distribution and Allowances (TDA) is transferred to the new TASS TDA. The BDEs and RTIs have limited organic equipment to support mission requirements of the POI under the TASS. Major end items for instruction will continue to be borrowed from MTOE units, except for Ordnance Training Companies and the Region G Engineer Training Battalion, and other TASS Team approved exceptions. Equipment shortfalls will be identified as soon as possible to the United States Property and Fiscal Office (USP&FO). The USP&FO will try to obtain the required equipment from MTOE units. If a shortage still exists, it will be identified to the TASS BDE and the RCE. The BDEs and RCEs will coordinate within their respective regions to support the mission. If the efforts of the USP&FO, BDEs and RCEs to obtain required equipment are unsuccessful and the equipment requirement has a unilateral benefit for all TASS TDAs, a fully justified and substantiated TDA change request can be submitted to the TASS AOMOCC for full NGB staff review and recommenda-

tion. This process will be in effect as described in paragraph 13-2c(2) below.

**c. Personnel.**

(1) **TDA's.** The BDE and RTI TDAs are built from existing assets, additional TDA spaces allocated by the STARCs, and additional billpayers allocated by NGB. Adjunct faculty and staff may augment the current personnel on the TDA through ADSW and additional AT periods.

(2) **Changes to TDAs (AOMOCC Process).** The NGB has initiated a process to review all requested TDA changes. All requested changes will go to NGB-ARF-IC. An Action Officer Management of Change Committee (AOMOCC) has been formed to address the requested changes. The committee consists of an advisory group comprised of NGB directorate members and a functional group comprised of members from various states from all seven TASS regions. The committee meets on an as needed basis to review state requests for TDA changes that may identify systemic changes. The committee reviews the issues and proposes a resolution for the best for the ARNG. The AOMOCC is not a permanent committee. As TASS evolves, the TASS TDAs will stabilize and the committee will no longer be needed. Once the committee dissolves, changes will go through NGB-ARF-IC for action.

(3) **Medical Support.** Medical support personnel have been moved from the TASS TDAs to the STARCs to consolidate all medical support for training. Medical Support for the TASS organizations will be provided by the STARC Medical Detachment.

(4) **Dining Facility Support.** The food service personnel will be shifted from the TASS TDAs to the Training Site TDAs once the Training Site TDAs are implemented. This will consolidate TDA food service support under the Training Site in support of the TASS organization and other tenant units. The TASS organizations that are not co-located on a training site will retain their food service personnel in their TASS TDA.

(5) **Maintenance Support.** Since major end items are not authorized in Section III of the TASS TDAs, all maintenance personnel will be removed from the TASS TDAs and consolidated at the STARC. This will occur along with the implementation of the Training Site TDA. Each TASS organization will be authorized an E7 Motor Sergeant to manage the PMCS program of the unit. Maintenance support will be coordinated through the STARC.

(6) **Title XI Support.** The assignment of Title XI personnel to the functionally aligned Training Battalions will also augment TDA personnel.

(7) **Chaplain.** TASS Chaplain support will be provided by the Chaplain Section of the STARC TDA. A determination of the required resources must be accomplished for each state.

**13-3. Functions and responsibilities of the TASS staff**

To include but not limited to:

**a. S1.**

- (1) Provides RTI/BDE strength maintenance.

- (2) Provides Administrative/Personnel service support to the schoolhouse.

- (3) Manages safety and accident prevention programs.

- (4) Provides academic record support to the schoolhouse.

- (5) Manages Headquarters of schoolhouse.

**b. S3.**

- (1) Executes training requirements within the state.

- (2) Maintains a current operation capabilities and properly forecasting future schoolhouse requirements.

- (3) Prepares and publishes overall command SOPs for schoolhouse operations.

- (4) Assigns missions to subordinate TASS TNG BNs.

- (5) Prioritizes and allocates critical resources of the command.

- (6) Identifies all training requirements of subordinate units.

- (7) Prepares and executes training programs, directives and orders.

- (8) Plans and conducts training inspections and evaluations.

- (9) Forecasts and programs ammunition requirements.

**c. S4.**

- (1) Ensures Logistics support occurs for the TNG BNs and companies in the state.

- (2) Coordinates ammunition procurement, storage, issue and turn-in.

- (3) Identifies cross component resourcing problems to the BDE.

- (4) Coordinates to acquire all needed equipment to satisfy training requirements.

- (5) Ensures that all borrowed equipment is returned in 10/20 standards.

**Chapter 14**

**Multi-Functional Training Brigades**

**14-1. OCONUS ARNG TASS Multi-Functional Training Brigades**

The ARNG has two regions which have Outside Continental United States (OCONUS) training institutions, Region C and G. These training institutions present unique situations because of their proximity to other training facilities. The OCONUS training institutions conduct most training independently. The creation of Multi-Functional Training Brigades satisfies the need for unique individual training for these OCONUS training institutions. Through the state TAGs, the NGB has coordinating authority with these Brigades for their training missions. See Figure 2-2 for the organizational chart and see Figure 14-1 and Figure 14-2 below for graphic representation..

**14-2. Region C**

Puerto Rico is the Caribbean Multifunctional Training Brigade. This organization has responsibility for both leadership and combat arms training. The U.S. Virgin Islands is a RTI with an NCOES mission under the

Caribbean Multi-Functional Brigade's GS TNG BN. CASCOM performs the equivalent of functional alignment for the Caribbean Multi-Functional Training Brigade.

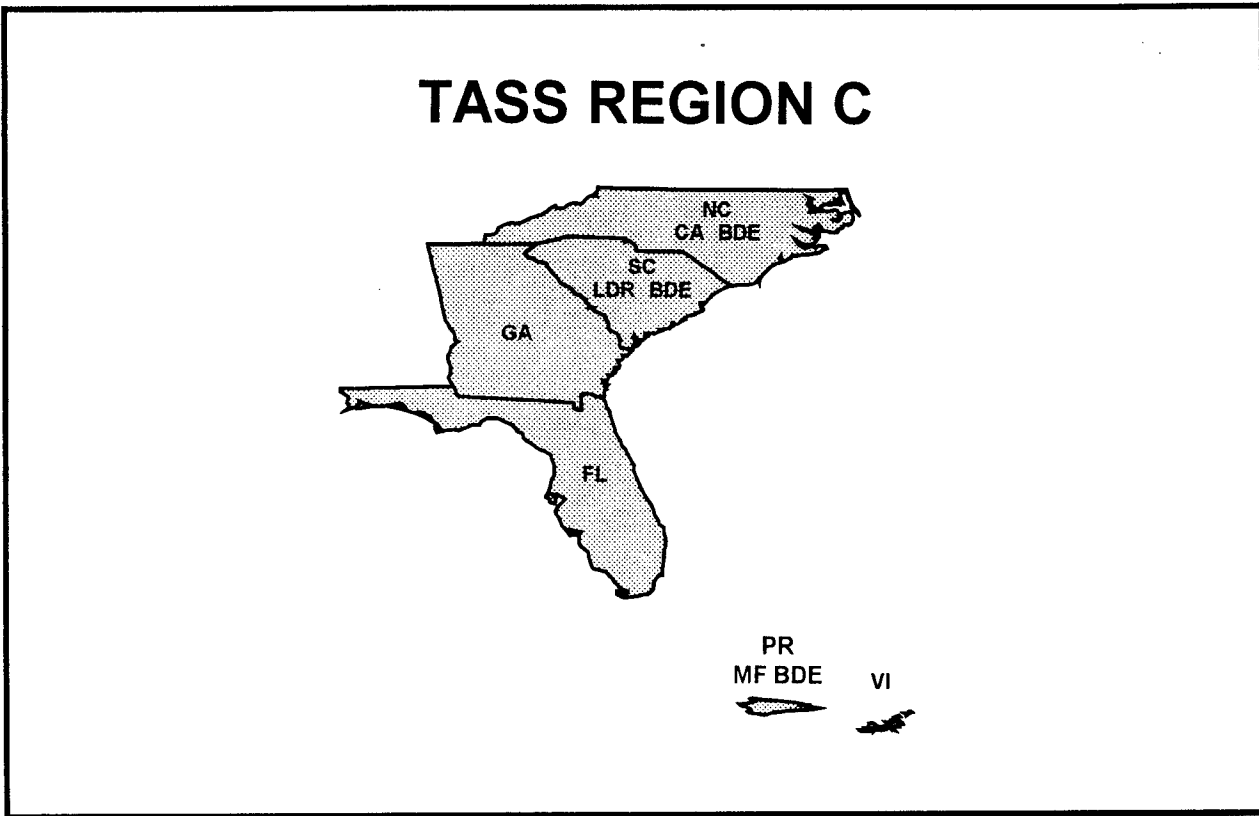

Figure 14-1. TASS Region C

**14-3. Region G**

Region G includes the Arctic Multi-Functional Training Brigade (Alaska) and the Pacific Multi-Functional Training Brigade (Hawaii). The Guam RTI is responsible for NCOES instruction in coordination with the Pacific Multi-Functional TNG BDE's GS TNG BN. The Infantry School performs the equivalent of functional alignment for both the Pacific and Arctic BDEs.

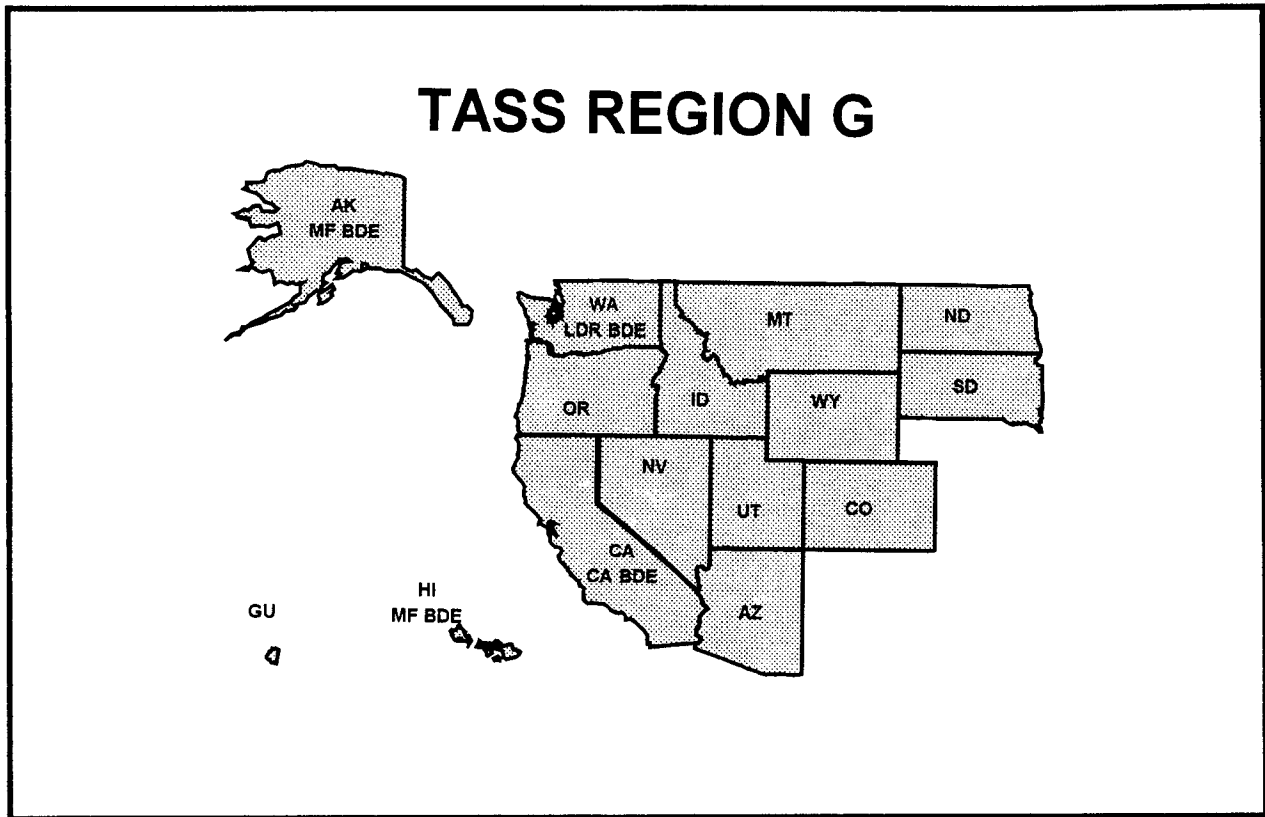

Figure 14-2. TASS Region G

**Glossary**

**AC**

Active Component

**ADSW**

Active Duty Special Work

**ADT**

Active Duty for Training

**ANCOC**

Advanced Noncommissioned Officer Course

**AOMOCC**

Action Officer Management Of Change Committee

**AR**

Army Regulation

**ARNG**

Army National Guard

**ARPRINT**

Army Program for Individual Training

**ASM**

ASM Research, Inc. (Civilian contractor for ATRRS)

**AT**

Annual Training

**ATRRS**

Army Training Requirements and Resource System

**ATSC**

Army Training Support Center

**BNCOC**

Basic Noncommissioned Officer Course

**CACI**

CACI Systems, Software and Simulation (Civilian contractor)

**CONUSA**

Continental United States Army

**DA**

Department of the Army

**DCSOPS**

Deputy Chief of Staff for Operations

**DCSPER**

Deputy Chief of Staff for Personnel

**FORSCOM**

United States Army Forces Command

**IDT**

Inactive Duty Training

**ITD**

Individual Training Directorate

**ITRM**

Individual Training Resource Model

**MACOM**

Major Army Command

**MOA**

Memorandum Of Agreement

**MOU**

Memorandum Of Understanding

**NCOES**

Noncommissioned Officer Education System

**NGB**

National Guard Bureau

**PEC**

Professional Education Center

**PLDC**

Primary Leadership Development Course

**POI**

Program of Instruction

**POM**

Program Objective Memorandum

**POTO**

Plans, Operations, and Training Officer

**RC**

Reserve Component

**RCE**

Regional Coordinating Element

**RC3**

Reserve Component Configured Course

**RTI**

Regional Training Institute

**RTS**

Regional Training Site

**RTS-M**

Regional Training Site-Maintenance or Medical

**SMDR**

Structure Manning Decision Review

**TASS**

Total Army School System

**TATS-C**

Total Army Training System-Courseware

**TCE**

TRADOC Coordinating Element

**TDA**

Table of Distribution and Allowance

**TDAD**

Training Development and Analysis Directorate

**TDY**

Temporary Duty

**TO&E**

Table of Organization and Equipment

**TOMA**

Training Operations Management Activity

**TRADOC**

United States Army Training and Doctrine Command

**TRAP**

Training Requirement Arbitration Program

**UCMJ**

Uniform Code of Military Justice

**USAR**

United States Army Reserve

**USARC**

United States Army Reserve Command

**USASMA**

United States Army Sergeants Major Academy

**USASSI**

United States Army Soldier Support Institute